

# MST SLOTTING CUTTER

Full range from 1.6 to 23.3mm in 3 types



## MSTA

- For narrow groove
- Self-clamping type
- Slot Width 1.6~4.0mm

## MSTB

- For middle groove
- Semi-adjustable type
- Slot Width 6.0~13.0mm

## MSTC

- For wide groove
- Full-adjustable type
- Slot Width 14.0~23.3mm

# MSTA

Slot width 1.6 2.2 3.0 4.0mm

## Self-clamping Slot Mills

MSTA Slot Mills have simple self-clamping system to allow for easy attachment by just installing the insert.

## Highly rigid clamping system

Holders achieve high operability through the stopper highly rigid clamping system and achieve stable slotting by maintaining an accurate edge position.

## 2 Prism Clamping system

High replacement precision due to the clamping system with two prisms.

## Easy replacement

The replacement of inserts is easy and quick by using special wrench.

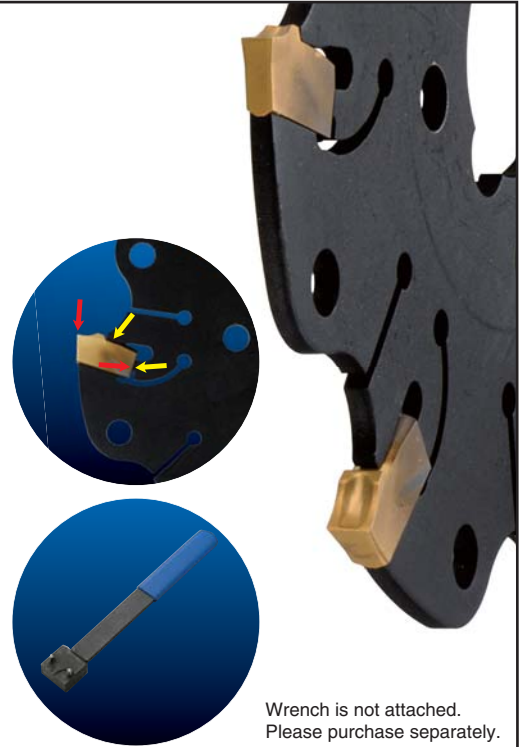

Wrench is not attached. Please purchase separately.

Slot width 6.0~13.0mm

## Up-right type / semi-adjustable groove width

## Inserts have four edge and are, therefore, cost-effective

Note : Inserts for 6mm slotting width has two edges.

## Easy and secure screw holding

MSTB Slot Mills are a very simple form used to screw clamp inserts.

## Applicable to a variety of slotting by choosing different inserts

By changing the thickness of inserts, it's applicable to various slotting widths up to max 1mm in 0.5mm increments.

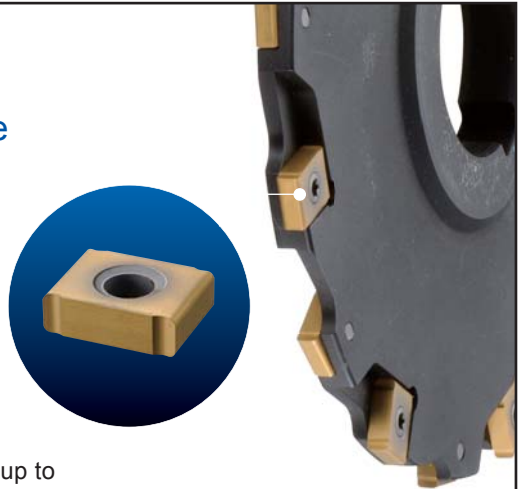

## Full lineup of MST Series Slot Mills

Type	Applicable Insert	Feature	Slot width (mm)															
			1.6	2.2	3	4	6	8	10	12	14	16	18	20	22	24		
<b>MSTA</b> Type	SLT..	1.6mm - 4mm fixed	●	●	●	●												
<b>MSTB</b> Type	LNEU12..	6mm - 13mm semi adjustable					▶											
<b>MSTC</b> Type	SP..10T3..	14mm - 18mm fully adjustable										▶						
	SD..1204...	18mm - 23.3mm fully adjustable													▶			

# MSTC

Slot width 14.0~23.3mm

Lay-down type / fully adjustable slot width

Applicable to various slotting needs. Slotting widths: 14.0mm to 23.3mm.

Cutter diameters: 100mm to 160mm.

Smooth slotting width adjustment can be available by unique cam style adjustment mechanism.

Four-edges inserts that are cost-effective.

Wide range corner R repertoires are suitable for various work.

By wiper edge insert, excellent surface finish can be expected.

By abundant insert geometry and grades, applicable for various type of workpiece machining.

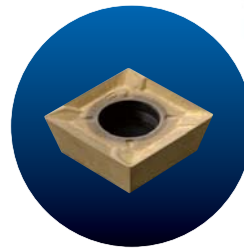

Insert		
Symbol	Rake Angle	Shape
SB	5°	
SD	15°	
SE	20°	

## ■ Features of Insert Grades

### CA0835

- TiN+TiCN+Al<sub>2</sub>O<sub>3</sub> based CVD coating
- For carbon steel, alloy steel, stainless steel and nodular cast iron
- For middle to high speed cutting

### PR0725

- TiN+TiCN+TiN based PVD multi layer coating
- For carbon steel, alloy steel, stainless steel, heat resistant alloy and nodular cast iron
- For middle speed cutting

### PR0110

- TiB<sub>2</sub> based PVD coating
- For non ferrous metal such as aluminum alloy (Si < 10%) and titanium alloy
- For high speed cutting

## Shell Mount for half-side cutting

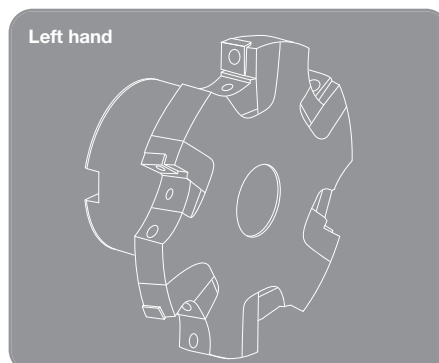
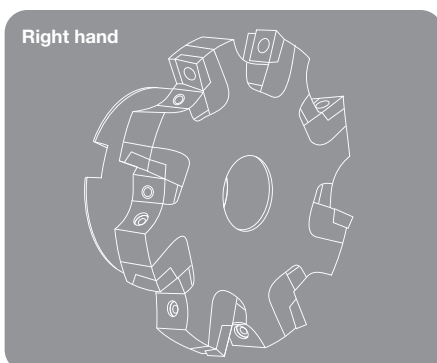

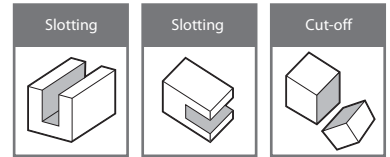

Toolholder

Identification System

< MSTA Type Slot Mill >

**MSTA** ○○○ **N** ○○○ - ○○○ **T**

Slot Mill with Self-Clamping System	Cutting Dia.	Neutral	Edge Width	No. of Insert
-------------------------------------	--------------	---------	------------	---------------

MSTA Type

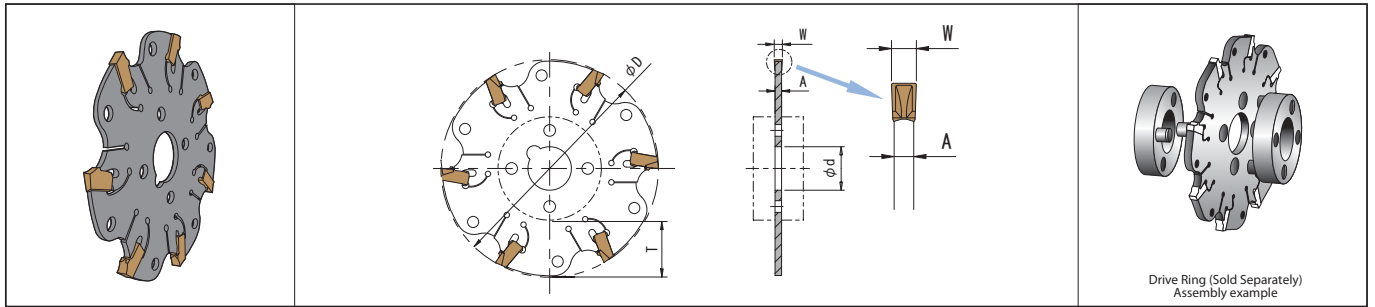

Drive Ring (Sold Separately)  
Assembly example

Toolholder Dimension

Description	Stock	Edge Width W (mm)	Slot Depth T (mm)	No. of Insert	Dimension (mm)			Weight (kg)	Applicable Insert See P5	Max.Revolution (min <sup>-1</sup> )	Spare parts	Recommended Cutting Condition	Example of Applicable Arbor																
					φ D	φ d (H7)	A				Wrench																		
MSTA 63N16-5T	●	1.6	15	5	63	16	1.3	SLT16...	5,100	MS-FRW1	See P5	See Back Page																	
MSTA 80N16-7T	●												21	7	80	16	0.03	4,000											
MSTA 100N16-9T	●												27	9	100	22	0.04	3,200											
MSTA 125N16-11T	●												35	11	125	32	0.07	2,600											
MSTA 63N22-5T	●	2.2	15	5	63	16	1.8	SLT22...	5,100	Wrench is not attached. Please purchase separately. Set up see P5.	See P5	See Back Page																	
MSTA 80N22-7T	●												21	7	80	16	0.03	4,000											
MSTA 100N22-9T	●												27	9	100	22	0.05	3,200											
MSTA 125N22-11T	●												35	11	125	32	0.08	2,600											
MSTA 160N22-14T	●												40	14	160	40	0.12	2,000											
MSTA 63N30-4T	●												3.0	15	4	63	16	2.4	SLT30...	5,100	See P5	See Back Page	See Back Page						
MSTA 80N30-6T	●	21	6	80	16	0.03	4,000																						
MSTA 100N30-9T	●	27	9	100	22	0.05	3,200																						
MSTA 125N30-11T	●	35	11	125	32	0.08	2,600																						
MSTA 160N30-14T	●	40	14	160	40	0.13	2,000																						
MSTA 63N40-4T	●	4.0	15	4	63	16	3.4	SLT40...	5,100	See P5	See Back Page	See Back Page																	
MSTA 80N40-6T	●																							21	6	80	16	0.06	4,000
MSTA 100N40-9T	●																							27	9	100	22	0.1	3,200
MSTA 125N40-11T	●												35	11	125	32	0.15	2,600											
MSTA 160N40-14T	●												40	14	160	40	0.25	2,000											
MSTA 63N40-4T	●												4.0	15	4	63	16	3.4	SLT40...	5,100	See P5	See Back Page	See Back Page						
MSTA 80N40-6T	●																							21	6	80	16	0.06	4,000
MSTA 100N40-9T	●																							27	9	100	22	0.1	3,200
MSTA 125N40-11T	●	35	11	125	32	0.15	2,600																						
MSTA 160N40-14T	●	40	14	160	40	0.4	2,000																						

Note) 1. Attach the drive ring (sold separately) to MSTA type slot mill to use. Drive ring is sold per single quantity. Please purchase two drive rings per one MSTA type slot mill.  
 2. Do not exceed the max revolution.  
 3. Do not operate cutting on reverse revolution.  
 4. Wrench (MS-FRW1) is not attached. Please purchase separately.

● : Std Stock

Drive Ring (mm spec)

Shape	Description	Stock	Dimension (mm)					Shape	Applicable Toolholder
			φ d	φ D	A1	a	φ d1		
	DR16-32A	●	16	32	8	4.1	3	Fig.2	MSTA 63N16-5T
	DR16-32B	●						Fig.1	MSTA 63N22-7T
	DR16-38	●	22	46	10	6.1	5	Fig.3	MSTA 63N30-4T
	DR22-46	●							MSTA 63N40-4T
	DR32-55	●							MSTA 80NOO-OT
	DR40-80	●							MSTA 100NOO-OT
	DR32-55	●	32	55	10	8.1	6	Fig.3	MSTA 125NOO-OOT
	DR40-80	●							MSTA 160NOO-OOT

Wrench and Drive Ring are sold 1 piece per 1 box.

● : Std Stock

Insert Description

Insert Identification System

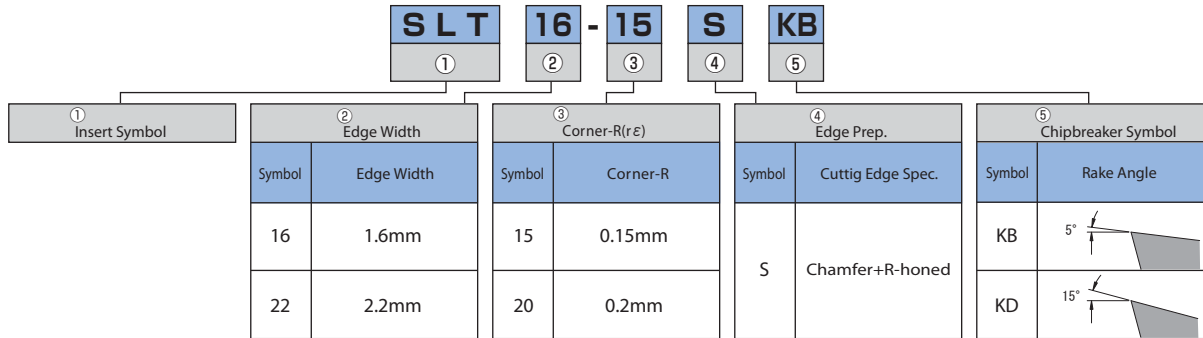

SLT Type

Shape	Description	Dimension (mm)		Angle (°)	CVD Coated carbide	PVD Coated carbide	Ref. Page for Toolholder
		w	rε	θ	CA0835	PR0735	
	SLT 16-15SKB	1.6 <sup>+0</sup> <sub>-0.1</sub>	0.15	5°	●	●	P3
		2.2 <sup>+0.08</sup> <sub>-0.05</sub>	0.2		○	●	
		3.0 <sup>+0.15</sup> <sub>-0</sub>			○	●	
		4.0 <sup>+0.15</sup> <sub>-0</sub>			○	●	
	SLT 16-15SKD	1.6 <sup>+0</sup> <sub>-0.1</sub>	0.15	15°	●	●	
		2.2 <sup>+0.08</sup> <sub>-0.05</sub>	0.2		○	●	
		3.0 <sup>+0.15</sup> <sub>-0</sub>			○	●	
		4.0 <sup>+0.15</sup> <sub>-0</sub>			○	●	

● Chipbreaker Selection

- KB... Conventional chipbreaker for steel and cast iron.
- KD... Low cutting force chipbreaker for stainless steel.

● : Std Stock

Features of Insert Grades

CA0835

- TiN+TiCN+Al<sub>2</sub>O<sub>3</sub> based CVD coated carbide
- For carbon steel, alloy steel, stainless steel and nodular cast iron
- For middle to high speed cutting

PR0735

- TiN based PVD coated carbide
- For stainless steel and heat resistant alloy
- For low to middle speed cutting

Inserts are sold in 10 piece per 1 box.

Set up

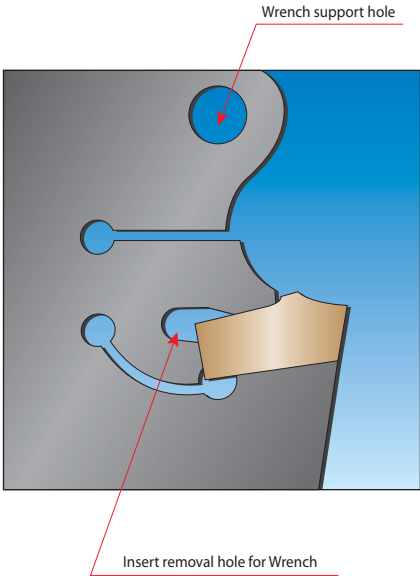

Wrench support hole

Insert removal hole for Wrench

IN indication example

OUT indication example

**How to attach inserts**

1. Put insert inside the slot mill.
2. Insert one of the pin on the wrench (on IN indicated side) into the wrench support hole.
3. Using the other pin, push the front relief surface of the insert.
4. Rotate the wrench until insert's back end makes contact with slot mill.

**How to detach inserts**

1. Insert one of the pin on the wrench (on OUT indicated side) into the wrench support hole, and insert other pin into the hole on releasing wrench.
2. Insert can be uninstalled by rotating the wrench counter clock wise. (A magnet is installed outside)

Note) Use appropriate wrench for set up

Recommended Cutting Condition

Workpiece Material	Hardness (HB)	Recommended Grade (Vc:m/min)		Feed per tooth fz (mm/t)				Remarks
		CVD coated carbide	PVD coated carbide	Edge width (mm)				
		CA0835	PR0735	1.6	2.2	3.0	4.0	
Low-carbon Steel	125	250 — 310	200 — 250	0.03 — 0.12	0.04 — 0.14	0.06 — 0.18	0.08 — 0.20	with coolant
Carbon Steel	190	160 — 190	130 — 160	0.03 — 0.12	0.04 — 0.14	0.06 — 0.18	0.08 — 0.20	
	250	140 — 180	110 — 150	0.03 — 0.12	0.04 — 0.14	0.06 — 0.18	0.08 — 0.20	
Alloy Steel	180	140 — 180	110 — 150	0.03 — 0.12	0.04 — 0.14	0.06 — 0.18	0.08 — 0.20	
	275	120 — 160	100 — 130	0.03 — 0.10	0.04 — 0.12	0.06 — 0.16	0.08 — 0.18	
High-carbon Alloy	280	100 — 140	80 — 120	0.03 — 0.10	0.04 — 0.12	0.06 — 0.16	0.08 — 0.18	
Stainless Steel	220	150 — 190	80 — 120	0.03 — 0.10	0.04 — 0.12	0.06 — 0.16	0.08 — 0.18	
	300	140 — 180	60 — 80	0.03 — 0.10	0.04 — 0.12	0.06 — 0.16	0.08 — 0.18	
Gray Cast Iron	260	160 — 200	—	0.03 — 0.12	0.04 — 0.14	0.06 — 0.18	0.08 — 0.20	without coolant
Nodular Cast Iron	160	130 — 160	—	0.03 — 0.12	0.04 — 0.14	0.06 — 0.18	0.08 — 0.20	
	250	110 — 140	—	0.03 — 0.12	0.04 — 0.14	0.06 — 0.18	0.08 — 0.20	

Note) 1. Use down-cut machining.  
 2. If D.O.C(ap) is under 1/10 of Cutter Dia (φD), it is possible to increase feed per tooth (fz) 40%.

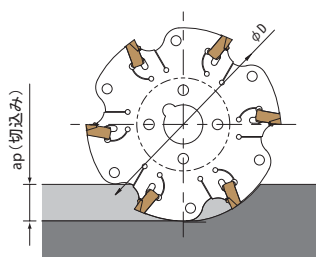

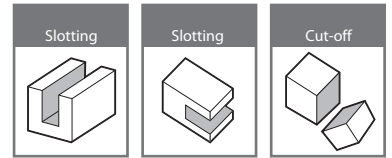

Toolholder

Identification System

<MSTB Type Slot Mill>

mm spec

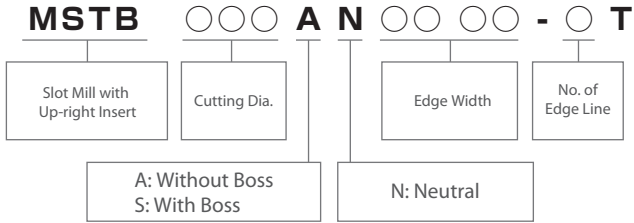

Arbor Mount

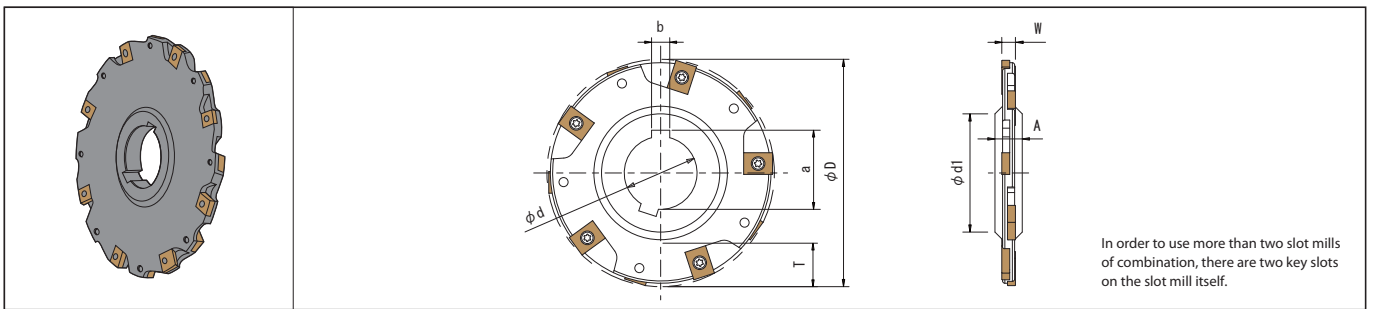

Toolholder Dimension

Description	Stock	Edge Width(mm)		Slot Depth	No. of Insert	No. of Edge Line	Dimension (mm)					Weight (kg)	Max. Revolution (min <sup>-1</sup> )	
		W (min)	W (max)	T (mm)			φ D	φ d (H7)	φ d1	A	a			b
MSTB 80AN0607-4T	●	6	7	15	8	4	80	27	44	12	29.8	7	0.3	9,240
MSTB 100AN0607-5T	●			21	10	5	100	32	52		34.8	8	0.4	8,270
MSTB 125AN0607-6T	●			28	12	6	125	40	63		43.5	10	0.7	7,390
MSTB 160AN0607-8T	●			45.5	16	8	160	40	63		43.5	10	1.1	6,540
MSTB 80AN0809-4T	●	8	9	16	8	4	80	27	44		29.8	7	0.4	9,240
MSTB 100AN0809-5T	●			22	10	5	100	32	52		34.8	8	0.5	8,270
MSTB 160AN0809-8T	●			45.5	16	8	160	40	63		43.5	10	1.3	6,450
MSTB 125AN1011-4T	●			10	11	30	12	4	125		40	63	43.5	10
MSTB 160AN1011-5T	●	47.5	15			5	160	1.6	6,450					
MSTB 160AN1213-5T	●	12	13			48.5	15	5	160					

● Std. Stock

## Shell Mount

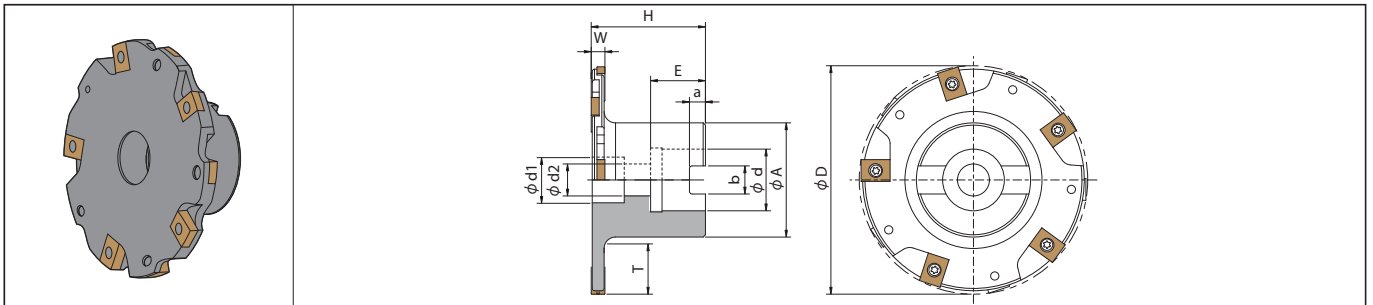

### Toolholder Dimension

Description	Stock	Edge Width(mm)		Slot Depth	No.of Insert	No.of Edge Line	Dimension (mm)									Weight (kg)	Max. Revolution (min <sup>-1</sup> )
		W (min)	W (max)				T (mm)	phi D	phi d (H7)	phi A	H (min)	E	a	b	phi d1		
MSTB 80SN0607-4T	●	6	7	16	8	4	80	22	40	50	23	6.3	10.4	18	12	0.7	9,240
100SN0607-5T	●			21	10	5	100	27	50		24	7	12.4	20	14	1.0	8,270
160SN0607-8T	●			41	16	8	160	40	70		28	9	16.4	33	22	1.9	6,540
MSTB 80SN0809-4T	●	8	9	16	8	4	80	22	40		23	6.3	10.4	18	12	0.8	9,240
100SN0809-5T	●			21	10	5	100	27	50		24	7	12.4	20	14	1.2	8,270
160SN0809-8T	●			41	16	8	160									2.2	6,540
MSTB 125SN1011-4T	●	10	11	26	12	4	125	40	70		28	9	16.4	33	22	2.0	7,390
160SN1011-5T	●			43	15	5	160									2.5	6,540

Note) 1. H(min) dimension shows in case of minimum of edge width.

● Std. Stock

## Spare Parts and Applicable Insert

### Spare Parts

Description		Spare Parts				Applicable Insert	Recommended Cutting Condition	Example of Applicable Arbor	
		Clamp Screw	Wrench	Anti-seize Compound	Mounting Bolt				
mm spec	Without Boss	MSTB 000AN0607-OT	SE-40050TR	TT-15L	MP- 1	—	See P8, P9	See P10	See Back Page
		000AN0809-OT	SE-40068TR						
		000AN1011-OT	SE-40090TR						
		160AN1213-5T	SE-40090TR						
	With Boss	MSTB 80SN0607-4T	SE-40050TR	TT-15L	MP- 1	HH10X35			
		100SN0607-5T				HH12X35			
		160SN0607-8T				HH20X40			
		MSTB 80SN0809-4T	SE-40068TR			HH10X35			
		100SN0809-5T				HH12X35			
		160SN0809-8T				HH20X40			
MSTB 000SN1011-OT	SE-40068TR		HH20X40						





 Coat anti-seize compound (MP-1) thinly on clamp screw when insert is fixed.

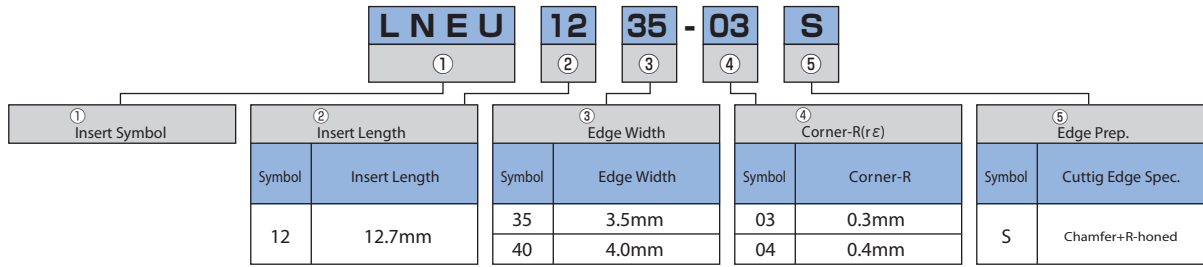

### Insert Identification System

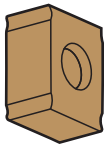
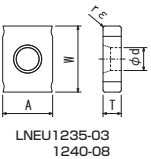
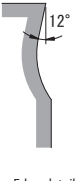
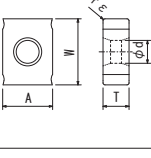
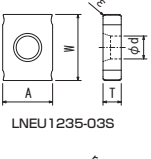
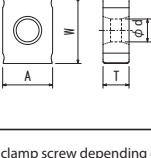
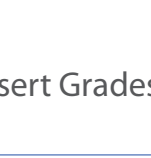
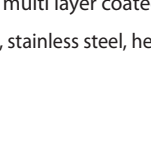

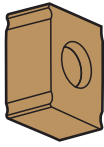
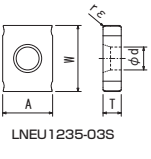
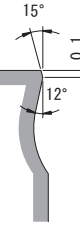
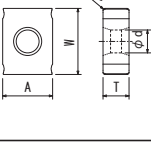
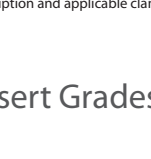
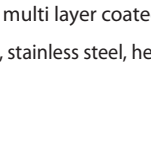
### LN Type

Description	W	A	φ d	Classification of usage ● : 1st Choice ○ : 2nd Choice	P Carbon Steel · Alloy Steel	M Stainless Steel	K Cast Iron	N Non-ferrous Material	S Heat-Resistant Alloy Titanium Alloy	Applicable Clamp Screw	Ref. Page for Toolholder	Ref. Page for Recommended Cutting Condition
						T	rε	PRO725				
LNEU12	12.7	9.6	4.4									
 Honed	 LNEU 1235-03 1240-08		 Edge detail	LNEU	1235-03	2	3.5	0.3	●	SE-40050TR	P6 P7	P10
	 LNEU 1235-03 1240-08			LNEU	1240-08	2	4.0	0.8	●	SE-40055TR		
	 LNEU 1235-03 1240-08			LNEU	1245-04	4	4.5	0.4	●	SE-40068TR		
	 LNEU 1235-03 1240-08			LNEU	1245-08			0.8	●			
	 LNEU 1235-03 1240-08			LNEU	1250-04	4	5.0	0.4	●	SE-40080TR		
	 LNEU 1235-03 1240-08			LNEU	1250-08			0.8	●			
	 LNEU 1235-03 1240-08			LNEU	1255-04	4	5.5	0.4	●	SE-40090TR		
	 LNEU 1235-03 1240-08			LNEU	1255-08			0.8	●			
 LNEU 1235-03 1240-08		LNEU	1260-04	4	6.0	0.4	●	SE-40100TR				
 Tough Edge	 LNEU 1235-03S		 Edge detail	LNEU	1235-03S	2	3.5	0.3	●	SE-40050TR		
	 LNEU 1235-03S			LNEU	1245-04S	4	4.5	0.4	●	SE-40068TR		
	 LNEU 1235-03S			LNEU	1245-08S			0.8	●			
	 LNEU 1235-03S			LNEU	1250-04S	4	5.0	0.4	●	SE-40080TR		
	 LNEU 1235-03S			LNEU	1250-08S			0.8	●			

Note) 1. Please select the applicable clamp screw depending on each insert description.  
 2. See page 10 for insert description and applicable clamp screw depending on edge width.

● : Std Stock

### Features of Insert Grades

#### PRO725

- TiN+TiCN+TiN based PVD multi layer coated carbide
- For carbon steel, alloy steel, stainless steel, heat resistant alloy and nodular cast iron
- For middle speed cutting

Inserts are sold in 10 piece per 1 box.

## Combination of applicable insert

Description	Clamp Screw (Standard attachment parts)	Edge Width		A Line		B Line		C Line		Wrench For Clamp Screw	Tightening Torque (Nm)	
		mm	inch (mm)	Applicable Insert	Clamp Screw	Applicable Insert	Clamp Screw	Applicable Insert	Clamp Screw			
mm spec	MSTB ○○○AN0607-OT ○○○SN0607-OT	SE-40050TR	6	—	LNEU1235..	SE-40050TR	—	—	LNEU1235..	SE-40050TR	TT-15L	3
			6.5		LNEU1240..	SE-40055TR			LNEU1240..	SE-40055TR		
			7		LNEU1245..	SE-40068TR			LNEU1245..	SE-40068TR		
	MSTB ○○○AN0809-OT ○○○SN0809-OT	SE-40068TR	8	—	LNEU1245..	SE-40068TR	—	—	LNEU1245..	SE-40068TR		
			8.5		LNEU1250..	SE-40080TR			LNEU1250..	SE-40080TR		
			9		LNEU1245..	SE-40068TR			LNEU1245..	SE-40068TR		
	MSTB ○○○AN1011-OT ○○○SN1011-OT	SE-40068TR	10	—	LNEU1245..	SE-40068TR	LNEU1245..	SE-40068TR	LNEU1245..	SE-40068TR		
			10.5		LNEU1250..	SE-40080TR	LNEU1250..	SE-40080TR	LNEU1250..	SE-40080TR		
			11		LNEU1255...	SE-40090TR	LNEU1255...	SE-40090TR	LNEU1255...	SE-40090TR		
	MSTB ○○○AN1213-OT	SE-40090TR	12	—	LNEU1255...	SE-40090TR	LNEU1255...	SE-40090TR	LNEU1255...	SE-40090TR		
			12.5		LNEU1260...	SE-40100TR	LNEU1260...	SE-40100TR	LNEU1260...	SE-40100TR		
			13		LNEU1260...	SE-40100TR	LNEU1260...	SE-40100TR	LNEU1260...	SE-40100TR		

For clamp screw, above listed "Standard attachment parts" are attached. In case of necessity of another size of clamp screw by changing slotting width, please purchase separately.

## Slot width (edge width) adjustment

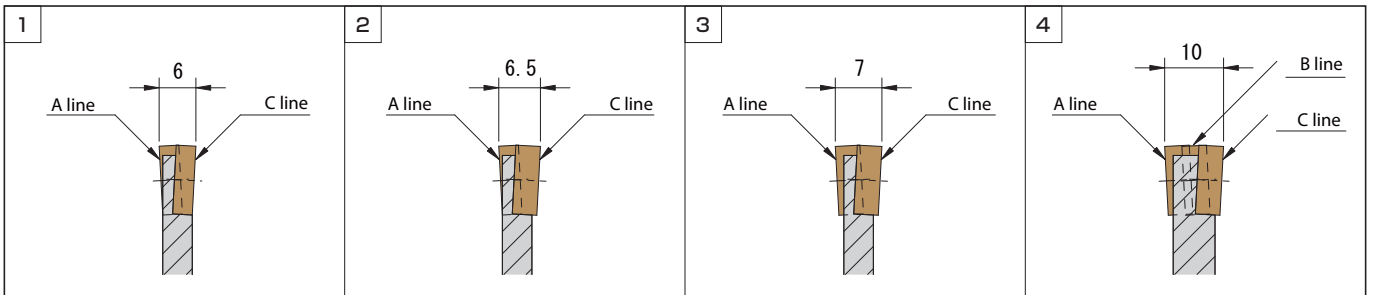

The Slot width (edge width) of MSTB-Type slot Mills is adjustable by a maximum of 1mm (.039") with the combination of inserts.

- In the case of MSTB ○○○AN0607-OT the width (W) is 6mm by installing LNEU1235 on both A line and C line.
- By replacing C line only with LNEU1240 the width (W) is 6.5mm.
- By replacing A line and C line with LNEU1240 the width (W) is 7mm.
- If the slotting width (edge width) is 10mm (.375"), the B line (middle edge) is necessary.

※ Note

- There is no description such as "A line", "B line", and "C line" on the actual slot Mill. These are only for explanation of the combination of insert.
- Use proper clamp screws for applicable inserts on the basis of the above chart.
- Please do not use, that has a difference of width more than 1mm (.039").

Recommended Cutting Condition

Workpiece Material	Hardness (HB)	Recommended Grade (Vc:m/min)		Feed per tooth fz (mm/t)		Remarks
		PVD coated carbide		Insert Thickness (mm)		
		PR0725		3.5 ~ 4.0	4.5 ~ 6.0	
Low-carbon Steel	125	170 — 210	0.07 — 0.20	0.10 — 0.22	without coolant	
Carbon Steel	190	100 — 140	0.07 — 0.20	0.10 — 0.22		
	250	90 — 120	0.07 — 0.20	0.10 — 0.22		
Alloy Steel	180	90 — 120	0.07 — 0.20	0.10 — 0.22		
	275	80 — 110	0.05 — 0.18	0.08 — 0.20		
High-carbon Alloy	280	70 — 90	0.05 — 0.18	0.08 — 0.20		
Stainless Steel	220	110 — 140	0.05 — 0.18	0.08 — 0.20	with coolant	
	300	100 — 120	0.05 — 0.18	0.08 — 0.20		
Heat-Resistant Alloy	350	15 — 30	0.05 — 0.18	0.08 — 0.20		
Titanium Alloy	270	20 — 50	0.05 — 0.18	0.08 — 0.20		
Gray Cast Iron	260	110 — 130	0.07 — 0.22	0.10 — 0.25	without coolant	
Nodular Cast Iron	160	80 — 100	0.07 — 0.22	0.10 — 0.25		
	250	70 — 90	0.07 — 0.22	0.10 — 0.25		

Note)

1. Use down-cut machining.
2. If D.O.C (ap) is under 1/10 of Cutter Dia ( $\phi D$ ), it is possible to increase feed per tooth (fz) 40%.

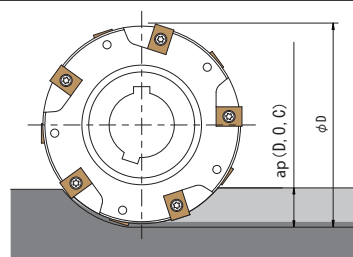

<MSTC Type Slot Mill>

■ Identification System

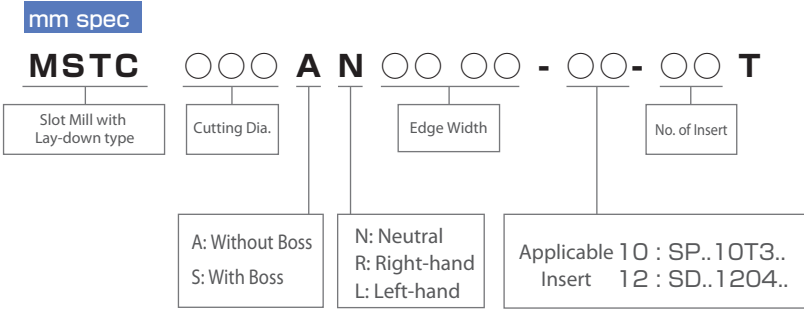

■ Machining direction of MSTC type slot mill

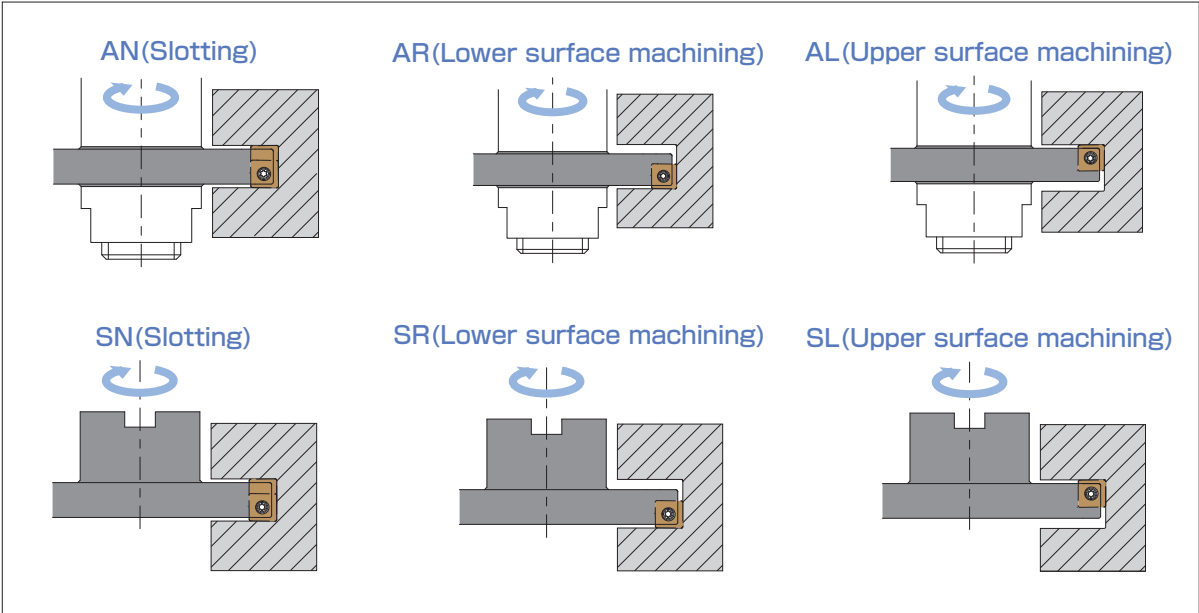

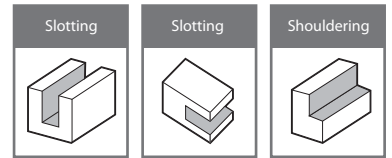

Toolholder

Arbor Mount

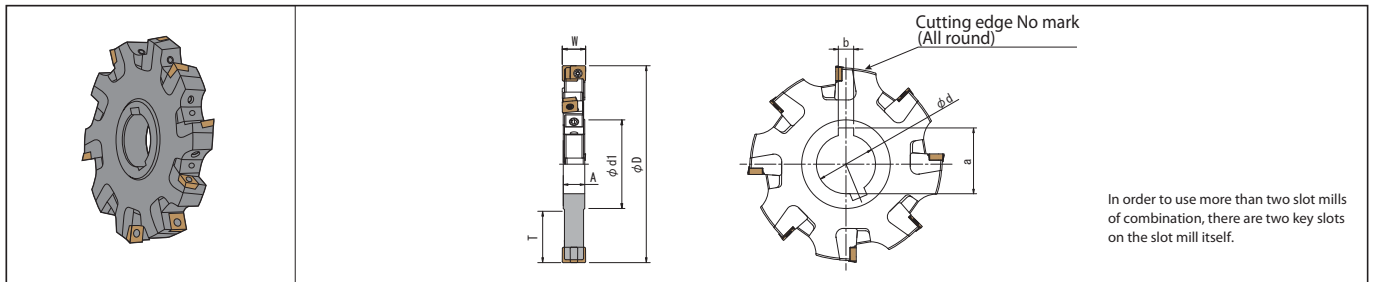

Toolholder Dimension

Description	Stock	Edge Width (mm)		Slot Depth T (mm)	No. of Insert	No. of Edge Line	Dimension (mm)						Weight (kg)	Max. Revolution (min <sup>-1</sup> )
		W (min)	W (max)				phi D	phi d (H7)	phi d1	A	a	b		
MSTC 100AN1416-10-3T	●	14	16	25.9	6	3	100	32	46.8	13.9	34.8	8	0.5	17,250
MSTC 125AN1416-10-4T	●			34.4	8	4	125							
MSTC 160AN1416-10-5T	●			51.9	10	5	160							
MSTC 125AN1618-10-4T	●	16	18	34.4	8	4	125	40	54.8	15.9	43.5	10	1.0	15,450
MSTC 160AN1618-10-5T	●			51.9	10	5	160							
MSTC 125AN1820-12-4T	●			34	8	4	125							
MSTC 160AN1820-12-5T	●	18	20.7	51.5	10	5	160	20.8	18.2	1.8	10,350	1.0	10,350	
MSTC 125AN2123-12-4T	●			34	8	4	125							
MSTC 160AN2123-12-5T	●			51.5	10	5	160							

● : Std Stock

Shell Mount

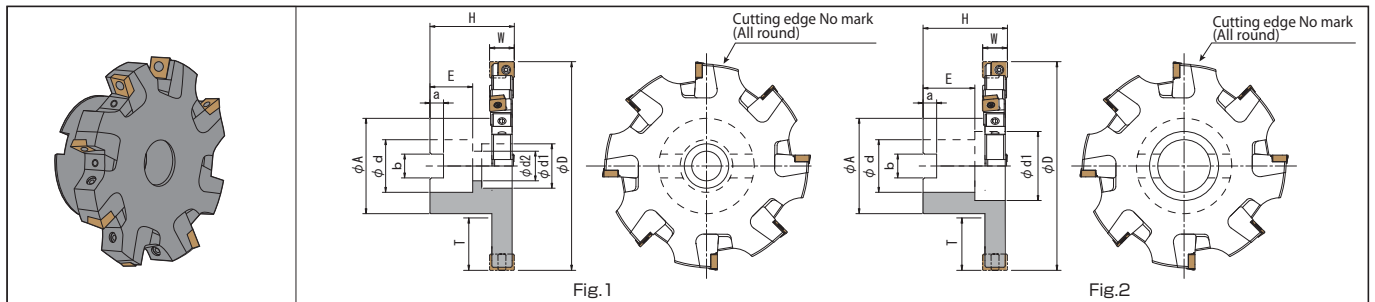

Fig.1

Fig.2

Toolholder Dimension

Description	Stock	Edge Width (mm)		Slot Depth T (mm)	No. of Insert	No. of Edge Line	Dimension (mm)										Shape	Weight (kg)	Max. Revolution (min <sup>-1</sup> )		
		W (min)	W (max)				phi D	phi d (H7)	phi A	H (min)	E	a	b	phi d1	phi d2						
MSTC 100SN1416-10-3T	●	14	16	24.4	6	3	100	27	48	50.8	24	7	12.4	20	14	Fig.1	1.0	17,250			
MSTC 125SN1416-10-4T	●			31.9	8	4	125	32	58		26	8	14.4	27	18						
MSTC 160SN1416-10-5T	●			43.4	10	5	160	40	70		30	9	16.4	56	—				Fig.2	2.0	13,650
MSTC 125SN1618-10-4T	●	16	18	31.9	8	4	125	32	58	50.8	26	8	14.4	27	18	Fig.1	1.7	15,450			
MSTC 160SN1618-10-5T	●			43.4	10	5	160	40	70		30	9	16.4	56	—				Fig.2	2.3	13,650
MSTC 125SN1820-12-4T	●			31.9	8	4	125	32	58		26	8	14.4	27	18				Fig.1	1.6	10,350
MSTC 160SN1820-12-5T	●	43.4	10	5	160	40	70	30	9	16.4	56	—	Fig.2	2.3	9,150						
MSTC 125SN2123-12-4T	●	20.7	23.3	31.9	8	4	125	32	58	51.0	26	8	14.4	27	18	Fig.1	1.7	10,350			
MSTC 160SN2123-12-5T	●			43.4	10	5	160	40	70		30	9	16.4	56	—				Fig.2	2.6	9,150

Note) 1. H(min) dimension shows in case of minimum of edge width.

● : Std Stock

Applicable Insert

Description	Edge No. (Marked)	Applicable Insert → see P17-P18	
		With hand	Neutral
MSTC...AN...10..	Location of odd No	SP..10T3...R...	SP..10T3...N...
MSTC...SN...10..	Location of even No	SP..10T3...L...	
MSTC...AN...12..	Location of odd No	SD..1204...R...	SD..1204...N...
MSTC...SN...12..	Location of even No	SD..1204...L...	

Recommended Cutting Conditions P19.

In case of attaching handed insert on above slottmill, same number of dege line right handed and left handed inserts are necessary.

Spare Parts

• For spare parts, see P15.

Slot width (edge with) adjustment

• See P20-P22.

Example of Applicable Arbor

• See Back page.

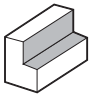

### Arbor Mount Right-hand

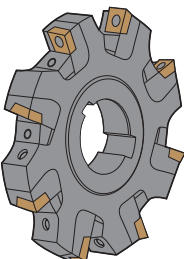

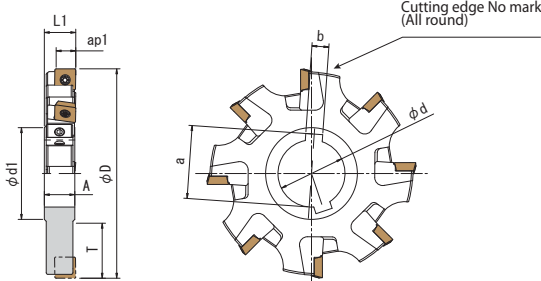

Cutting edge No mark  
(All round)

In order to use more than two slot mills of combination, there are two key slots on the slot mill itself.

※ Right-hand shown

#### Toolholder Dimension

Description	Stock	No. of Insert	Dimension (mm)											Weight (kg)	Max. Revolution (min <sup>-1</sup> )
			φD	φd (H7)	φd1	A	L1		T	ap1 (max)	a	b			
							(min)	(max)							
MSTC 100AR1416-10-6T	●	6	100	32	46.8	13.9	13.9	14.9	25.9	9.1	34.8	8	0.5	17,250	
MSTC 125AR1416-10-8T	●	8	125	40	54.8				34.4				0.8	15,450	
MSTC 160AR1416-10-10T	●	10	160	40	54.8				51.9				1.5	13,650	
MSTC 125AR1618-10-8T	●	8	125	40	54.8	15.9	15.2	16.2	34.4	9.1	43.5	10	1.0	15,450	
MSTC 160AR1618-10-10T	●	10	160						51.9				1.8	13,650	
MSTC 125AR1820-12-8T	●	8	125	40	54.8	18.2	18.1	19.4	34.0	11.7	43.5	10	1.0	10,350	
MSTC 160AR1820-12-10T	●	10	160						51.5				1.8	9,150	
MSTC 125AR2123-12-8T	●	8	125	40	54.8	20.8	20.7	22.0	34.0	11.7	43.5	10	1.2	10,350	
MSTC 160AR2123-12-10T	●	10	160						51.5				2.1	9,150	

● : Std Stock

### Shell Mount Right-hand

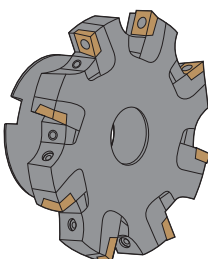

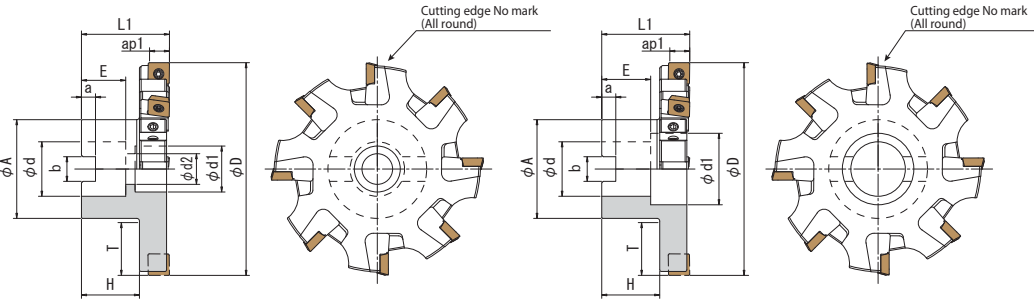

Cutting edge No mark  
(All round)

※ Right-hand shown

#### Toolholder Dimension

Description	Stock	No. of Insert	Dimension (mm)														Shape	Weight (kg)	Max. Revolution (min <sup>-1</sup> )
			φD	φd (H7)	φA	H	L1		T	ap1 (max)	E	a	b	φd1	φd2				
							(min)	(max)											
MSTC 100SR1416-10-6T	●	6	100	27	48	37.7	50.8	51.8	24.4	9.1	24	7	12.4	20	14	Fig.1	1.0	17,250	
MSTC 125SR1416-10-8T	●	8	125	32	58				31.9		26	8	14.4	27	18		1.6	15,450	
MSTC 160SR1416-10-10T	●	10	160	40	70				43.4		30	9	16.4	56	—		2.0	13,650	
MSTC 125SR1618-10-8T	●	8	125	32	58	35.7	50.8	51.8	31.9	9.1	26	8	14.4	27	18	Fig.1	1.7	15,450	
MSTC 160SR1618-10-10T	●	10	160	40	70				43.4		30	9	16.4	56	—		2.3	13,650	
MSTC 125SR1820-12-8T	●	8	125	32	58	34.0	51.0	52.3	31.9	11.7	26	8	14.4	27	18	Fig.1	1.6	10,350	
MSTC 160SR1820-12-10T	●	10	160	40	70				43.4		30	9	16.4	56	—		2.3	9,150	
MSTC 125SR2123-12-8T	●	8	125	32	58	31.4	51.0	52.3	31.9	11.7	26	8	14.4	27	18	Fig.1	1.7	10,350	
MSTC 160SR2123-12-10T	●	10	160	40	70				43.4		30	9	16.4	56	—		2.6	9,150	

● : Std Stock

#### Applicable Insert

Description	Applicable Insert → see P17-P18	
	With hand	Neutral
MSTC...AR...10.. MSTC...SR...10..	SP..10T3...R...	SP..10T3...N...
MSTC...AR...12.. MSTC...SR...12..	SD..1204...R...	SD..1204...N...

Recommended Cutting Conditions P19.

#### Spare Parts

• For spare parts, see P16.

#### Slot width (edge with) adjustment

• See P20-P22.

#### Example of Applicable Arbor

• See Back page.

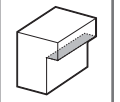
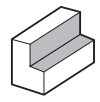

Toolholder

Arbor Mount Left-hand

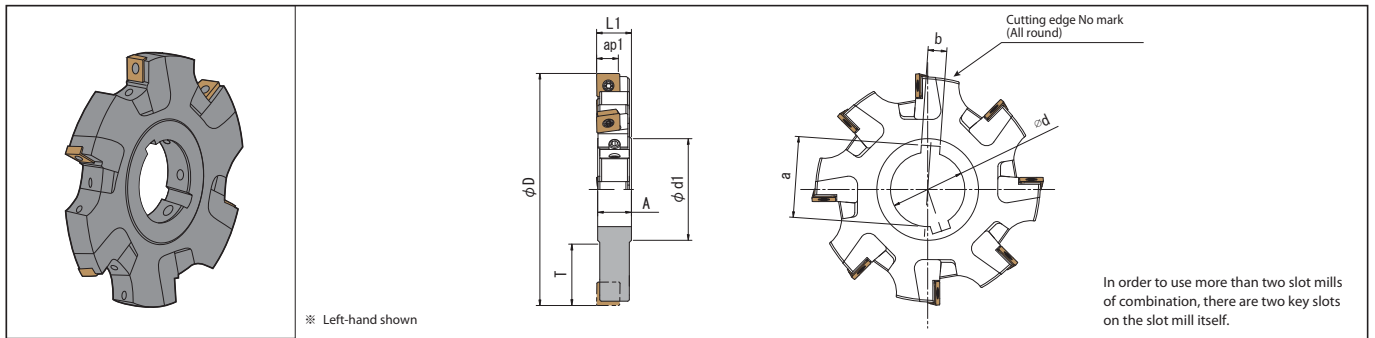

※ Left-hand shown

Toolholder Dimension

Description	Stock	No. of Insert	Dimension (mm)										Weight (kg)	Max. Revolution (min <sup>-1</sup> )									
			phi D	phi d (H7)	phi d1	A	L1		T	ap1 (max)	a	b											
							(min)	(max)															
MSTC 100AL1416-10-6T	●	6	100	32	46.8	13.9	13.9	14.9	25.9	9.1	34.8	8	0.5	17,250									
MSTC 125AL1416-10-8T	●	8	125	40	54.8										15.9	15.2	16.2	34.4	11.7	43.5	10	0.8	15,450
MSTC 160AL1416-10-10T	●	10	160																				
MSTC 125AL1618-10-8T	●	8	125			20.8	20.7	22.0	34.0	51.5	51.5	9,150	10,350										
MSTC 160AL1618-10-10T	●	10	160	1.2	10,350									9,150									
MSTC 125AL1820-12-8T	●	8	125												1.2	10,350	9,150						
MSTC 160AL1820-12-10T	●	10	160			2.1	9,150																
MSTC 125AL2123-12-8T	●	8	125	2.1	9,150																		
MSTC 160AL2123-12-10T	●	10	160																				

●: Std Stock

Shell Mount Left-hand

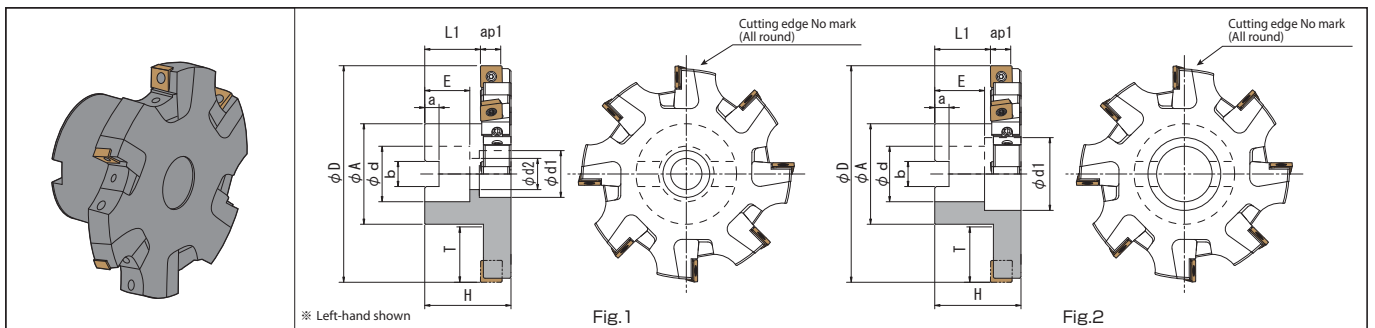

※ Left-hand shown

Fig.1

Fig.2

Toolholder Dimension

Description	Stock	No. of Insert	Dimension (mm)												Shape	Weight (kg)	Max. Revolution (min <sup>-1</sup> )														
			phi D	phi d (H7)	phi A	H	L1		T	ap1 (max)	E	a	b	phi d1				phi d2													
							(min)	(max)																							
MSTC 100SL1416-10-6T	●	6	100	27	48	50	35.8	36.8	31.9	9.1	24	7	12.4	20	14	Fig.1	1.0	17,250													
MSTC 125SL1416-10-8T	●	8	125	32	58														33.8	34.8	31.9	9.1	26	8	14.4	27	18	Fig.1	1.6	15,450	
MSTC 160SL1416-10-10T	●	10	160	40	70																										31.7
MSTC 125SL1618-10-8T	●	8	125	32	58	29.1	30.4	31.9	11.7	26	8	14.4	27	18	Fig.1	1.7	15,450														
MSTC 160SL1618-10-10T	●	10	160	40	70													26	8	14.4	27	18	30	9	16.4	56	—	Fig.2	2.3	13,650	
MSTC 125SL1820-12-8T	●	8	125	32	58																										26
MSTC 160SL1820-12-10T	●	10	160	40	70	26	8	14.4	27	18	30	9	16.4	56	—	Fig.2	2.3														
MSTC 125SL2123-12-8T	●	8	125	32	58													26	8	14.4	27	18	30	9	16.4	56	—	Fig.1	1.7	10,350	
MSTC 160SL2123-12-10T	●	10	160	40	70																										26

●: Std Stock

Applicable Insert

Description	Applicable Insert → see P17-P18	
	With hand	Neutral
MSTC...AL...10.. MSTC...SL...10..	SP..10T3...L...	SP..10T3...N...
MSTC...AL...12.. MSTC...SL...12..	SD..1204...L...	SD..1204...N...

Recommended Cutting Conditions P19.

Spare Parts

• For spare parts, see P16.

Slot width (edge with) adjustment

• See P20-P22.

Example of Applicable Arbor

• See Back page.

Spare Parts

Spare Parts

Description		Spare Parts															
		Cartridge		Wedge	Wedge Screw	Cam Pin	Clamp Screw	Wrench			Anti-seize Compound	Mounting Bolt					
		Right-hand	Left-hand					For Wedge Screw	For Cam Pin	For Clamp Screw							
Without Boss	mm spec	MSTC 100AN1416-10-3T	C90SP1416-10R	C90SP1416-10L	WC-14	W6 X 18	AP-1416	SE-3070TRP	TH-3L	LW-2.5	DTP-9	—					
		MSTC 125AN1416-10-4T				W6 X 20											
		MSTC 160AN1416-10-5T				W6 X 20											
	MSTC 125AN1618-10-4T	C90SP1618-10R	C90SP1618-10L	WC-16	W6 X 20	AP-1820	SB-3590TRP	LW-3		DTP-15							
	MSTC 160AN1618-10-5T				W6 X 20												
	MSTC 125AN1820-12-4T				C90SD1820-12R						C90SD1820-12L		WC-18	W6 X 20	AP-1820	SB-3590TRP	LW-3
MSTC 160AN1820-12-5T	W6 X 20																
MSTC 125AN2123-12-4T	C90SD2023-12R	C90SD2023-12L	WC-20	W6 X 20		AP-1820	SB-3590TRP	LW-3	DTP-15								
MSTC 160AN2123-12-5T				W6 X 20													
MSTC 100SN1416-10-3T				C90SP1416-10R	C90SP1416-10L					WC-14	W6 X 20	AP-1416	SE-3070TRP	LW-2.5	DTP-9		
MSTC 125SN1416-10-4T	W6 X 20																
MSTC 160SN1416-10-5T	W6 X 20																
With Boss	mm spec	MSTC 125SN1618-10-4T	C90SP1618-10R	C90SP1618-10L	WC-16	W6 X 20	AP-1820	SB-3590TRP	TH-3L	LW-3	DTP-15	HH12 X 35					
		MSTC 160SN1618-10-5T										W6 X 20	AP-1416	SE-3070TRP	LW-2.5	DTP-9	HH16 X 35
		MSTC 125SN1820-12-4T										C90SD1820-12R					C90SD1820-12L
		MSTC 160SN1820-12-5T	W6 X 20	—													
		MSTC 125SN2123-12-4T	C90SD2023-12R	C90SD2023-12L	WC-20	W6 X 20	AP-1820	SB-3590TRP		LW-3	DTP-15		HH16 X 35				
		MSTC 160SN2123-12-5T				W6 X 20						—					
MSTC 160SN2123-12-5T	W6 X 20	—															

 Coat anti-seize compound (MP-1) thinly on clamp screw when insert is fixed.



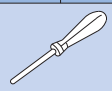







Tightening Torque / Slot Mill / (Lay down Type)

Wrench	TH-3L	DTP-9	DTP-15
			
Tightening Torque (Nm)	5-6	1.5	4



## Spare Parts

### Spare Parts

Description		Spare Parts												
		Cartridge		Wedge	Wedge Screw	Cam Pin	Clamp Screw	Wrench			Anti-seize Compound	Mounting Bolt		
		Right-hand	Left-hand					For Wedge Screw	For Cam Pin	For Clamp Screw				
														
Without Boss	mm spec	MSTC 100AR1416-10-6T 125AR1416-10-8T 160AR1416-10-10T	C90SP1416-10R	—	WC-14	W6 X 18	AP-1416	SE-3070TRP	TH-3L	LW-2.5	DTP-9	MP-1	—	
		MSTC 125AR1618-10-8T 160AR1618-10-10T			WC-16	W6 X 20								
		MSTC 125AR1820-12-8T 160AR1820-12-10T			WC-18	W6 X 20								
		MSTC 125AR2123-12-8T 160AR2123-12-10T			WC-20	W6 X 20								
		MSTC 100AL1416-10-6T 125AL1416-10-8T 160AL1416-10-10T			C90SP1416-10L	WC-14								W6 X 18
		MSTC 125AL1618-10-8T 160AL1618-10-10T				WC-16								W6 X 20
	MSTC 125AL1820-12-8T 160AL1820-12-10T	WC-18	W6 X 20											
	MSTC 125AL2123-12-8T 160AL2123-12-10T	WC-20	W6 X 20											
	MSTC 100SR1416-10-6T 125SR1416-10-8T 160SR1416-10-10T	C90SP1416-10R	—	WC-14		W6 X 20								
	MSTC 125SR1618-10-8T 160SR1618-10-10T			WC-16		W6 X 20								
	MSTC 125SR1820-12-8T 160SR1820-12-10T			WC-18	W6 X 20									
	MSTC 125SR2123-12-8T 160SR2123-12-10T			WC-20	W6 X 20									
MSTC 100SL1416-10-6T 125SL1416-10-8T 160SL1416-10-10T	C90SP1416-10L			—	WC-14	W6 X 20								
MSTC 125SL1618-10-8T 160SL1618-10-10T					WC-16	W6 X 20								
MSTC 125SL1820-12-8T 160SL1820-12-10T		WC-18	W6 X 20											
MSTC 125SL2123-12-8T 160SL2123-12-10T		WC-20	W6 X 20											

 Coat anti-seize compound (MP-1) thinly on clamp screw when insert is fixed.

## Tightening Torque / Half-Side Slot Mil

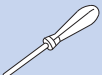
Wrench	TH-3L	DTP-9	DTP-15
			
Tightening Torque (Nm)	5-6	1.5	4

## Insert Identification System

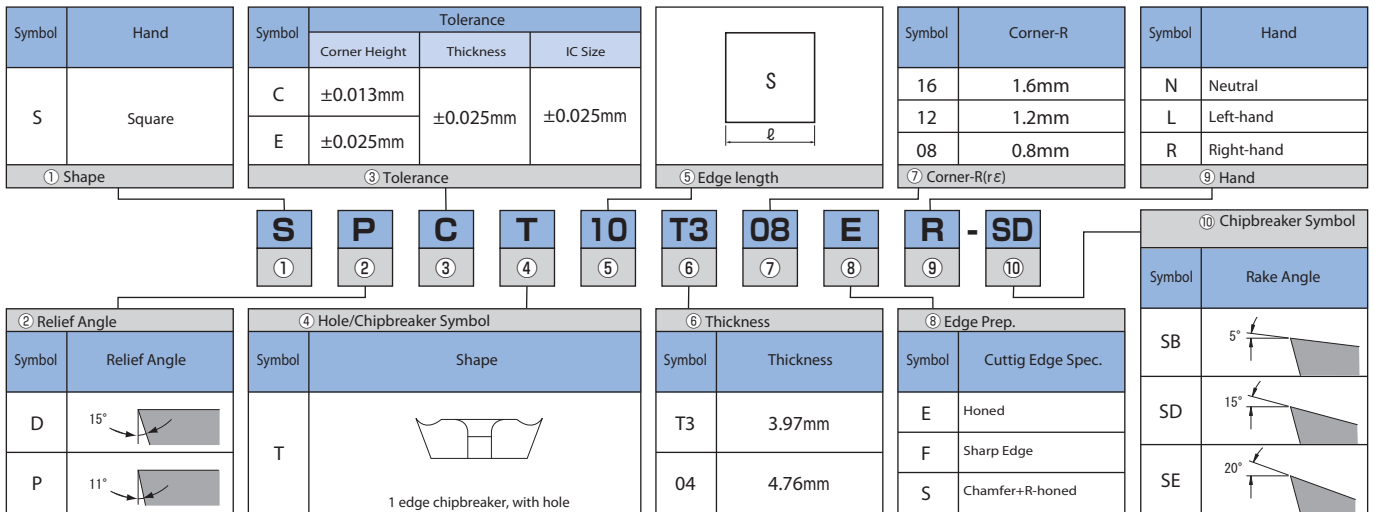

### Applicable Insert

## SP..10T3

Description	L1	T	φd	α	Classification of usage	P	M	K	N	S	Dimension (mm)			CVD coated carbide	PVD coated carbide
						Carbon Steel · Alloy Steel	Stainless Steel	Cast Iron	Non-ferrous Material	Heat-Resistant Alloy	Titanium Alloy	rε	Wiper Edge	CA0935	PR0725
SP..10T3	10.0	3.97	3.4	11°	● : 1st Choice ○ : 2nd Choice	●	○	○							
Shape	Handed Insert shows Right-hand				Description	No.of Edge	Dimension (mm)		CVD coated carbide	PVD coated carbide					
					SPCT 10T316EN-SD	4	1.6	—			●				
					SPCT 10T308E <sup>R</sup> /L-SD	4	0.8	2.5			●				
					SPCT 10T312E <sup>R</sup> /L-SD	4	1.2	1.8			●				
					SPCT 10T316FN-SE	4	1.6	—			●				
					SPCT 10T308F <sup>R</sup> /L-SE	4	0.8	2.7			●				
					SPCT 10T312F <sup>R</sup> /L-SE	4	1.2	2.2			●				
					SPET 10T308E <sup>R</sup> /L-SB	4	0.8	2.7	●	●	●				
					SPET 10T308S <sup>R</sup> /L-SB	4	0.8	2.7	●	●	●				

Inserts are sold in 10 piece per 1 box.

● : Std Stock

Applicable Insert

SD..1204

					Classification of usage ● : 1st Choice ○ : 2nd Choice	P	Carbon Steel · Alloy Steel	●	●			
						M	Stainless Steel	○	●			
					K	Cast Iron	○	●				
					N	Non-ferrous Material				●		
					S	Heat-Resistant Alloy				●		
					S	Titanium Alloy				○		
Description	A	T	φ d	α	Shape	Description	No.of Edge	Dimension (mm)		CVD coated carbide	PVD coated carbide	
								r ε	Wiper Edge	CA0835	PR0725	PR0110
SD..1204	12.7	4.76	4.4	15°	Handed Insert shows Right-hand							
						SDCT 120416EN-SD	4	1.6	—		●	
						SDCT 120408E <sup>R</sup> /L-SD	4	0.8	2.5		●	
						SDCT 120412E <sup>R</sup> /L-SD	4	1.2	1.8		●	
						SDCT 120416FN-SE	4	1.6	—			●
						SDCT 120408F <sup>R</sup> /L-SE	4	0.8	2.7			●
						SDCT 120412F <sup>R</sup> /L-SE	4	1.2	1.9			●
						SDET 120408E <sup>R</sup> /L-SB	4	0.8	2.5	●	●	
						SDET 120412E <sup>R</sup> /L-SB	4	1.2	1.8	●	●	
						SDET 120416SN-SB	4	1.6	—	●	●	
						SDET 120408S <sup>R</sup> /L-SB	4	0.8	2.5	●	●	

● : Std Stock

Inserts are sold in 10 piece per 1 box.

Features of Insert Grades

CA0835

- TiN+TiCN+Al<sub>2</sub>O<sub>3</sub> based CVD coated carbide
- For carbon steel, alloy steel, stainless steel and nodular cast iron
- For middle to high speed cutting

PR0725

- TiN+TiCN+TiN based PVD multi layer coated carbide
- For carbon steel, alloy steel, stainless steel, heat resistant alloy and nodular cast iron
- For middle speed cutting

PR0110

- TiB<sub>2</sub> based PVD coating
- For non ferrous metal such as aluminum alloy (Si < 10%) and titanium alloy
- For high speed cutting

Recommended Cutting Condition (For CA0835 / PR0725)

Workpiece Material	Hardness (HB)	Recommended Grade (Vc:m/min)		Feed per tooth fz (mm/t)			Remarks
		CVD coated carbide	PVD coated carbide	Chipbreaker Symbol			
		CA0835	PR0725	EN-SD ER-SD EL-SD	ER-SB EL-SB	SN-SB SR-SB SL-SB	
Low-carbon Steel	125	250 – 310	170 – 210	0.07– 0.20	0.10– 0.22	0.15– 0.3	without coolant
Carbon Steel	190	160 – 190	100 – 140	0.07– 0.20	0.10– 0.22	0.15– 0.3	
	250	140 – 180	90 – 120	0.07– 0.20	0.10– 0.22	0.15– 0.3	
Alloy Steel	180	140 – 180	90 – 120	0.07– 0.20	0.10– 0.22	0.15– 0.3	
	275	120 – 160	80 – 110	0.05– 0.18	0.08– 0.20	0.12– 0.25	
High-carbon Alloy	280	110 – 130	70 – 90	0.05– 0.18	0.08– 0.20	0.12– 0.25	with coolant
Stainless Steel	220	160 – 200	110 – 140	0.05– 0.18	0.08– 0.20	0.12– 0.25	
	300	150 – 180	100 – 120	0.05– 0.18	0.08– 0.20	0.12– 0.25	
Heat-Resistant Alloy	350	–	15 – 30	0.05– 0.18	0.08– 0.20	0.12– 0.25	
Titanium Alloy	270	–	20 – 50	0.05– 0.18	0.08– 0.20	0.12– 0.25	without coolant
Gray Cast Iron	260	160 – 200	110 – 130	0.07– 0.22	0.10– 0.25	0.15– 0.35	
Nodular Cast Iron	160	130 – 160	80 – 100	0.07– 0.22	0.10– 0.25	0.15– 0.35	
	250	110 – 140	70 – 90	0.07– 0.22	0.10– 0.25	0.15– 0.35	

Note) 1. Use down-cut machining.  
 2. If D.O.C(ap) is under 1/10 of Cutter Dia (φD), it is possible to increase feed per tooth (fz) 40%.

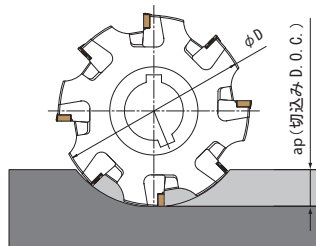

Recommended Cutting Condition (For PR0110)

Workpiece Material	Hardness (HB)	Recommended Grade (Vc:m/min)	Feed per tooth fz (mm/t)	Remarks
		PVD coated carbide	Chipbreaker Symbol	
		PR0110	FN-SE FR-SE FL-SE	
Non-ferrous Material	–	750 – 950	0.07– 0.20	with coolant

Note) 1. Use down-cut machining.  
 2. If D.O.C(ap) is under 1/10 of Cutter Dia (φD), it is possible to increase feed per tooth (fz) 40%.

# Slot width (edge width) adjustment of MSTC type Slotting Cutter

## Slot width (edge width) measurement

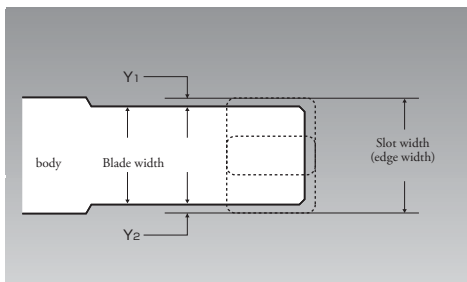
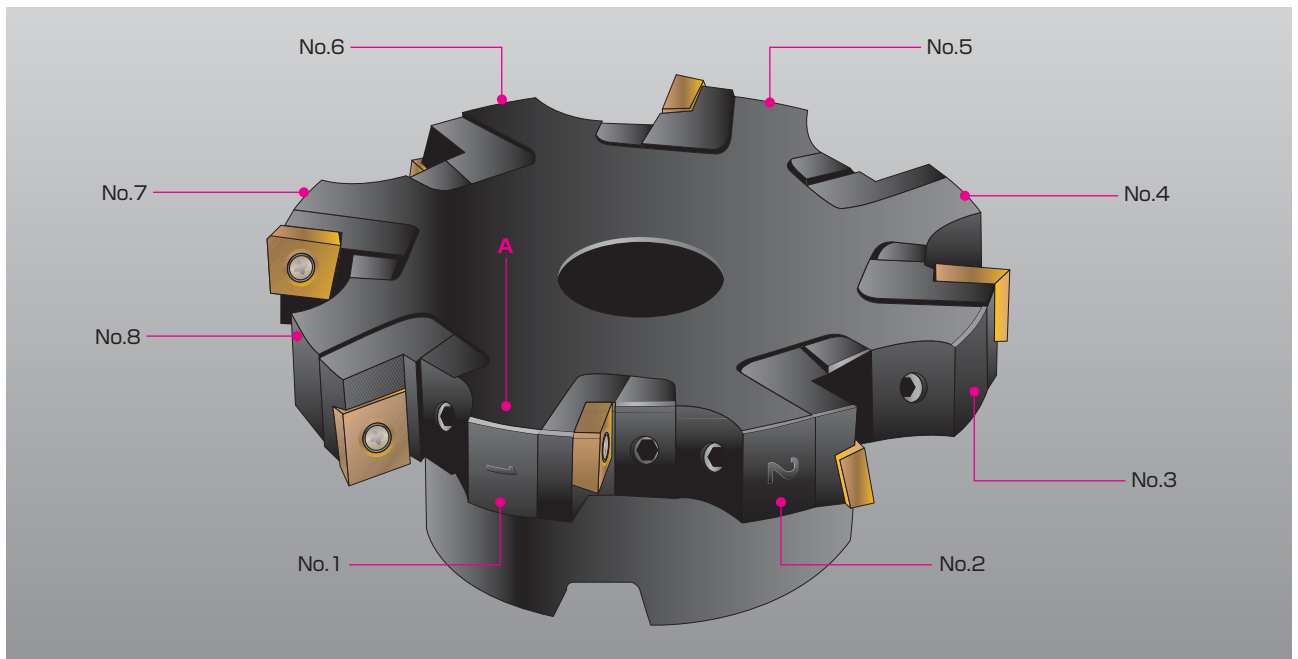

1. Please check slot mill edge location number. (The edge location number is marked on the slot mill body.)
2. Set up the slot mill on length measuring equipment such as tool presettlers.
3. Place the point A of the slot mill body near the position No.1 to "0 (zero)" of the length measuring equipment.
4. Move the length measuring equipment to the insert corner part and measure the step (Y1) between the point A and the insert No.1.
5. Likewise, measure the step between the slot mill body and the insert, and you will obtain the slot width (edge width).

## In the case of changing the slot width (edge width)

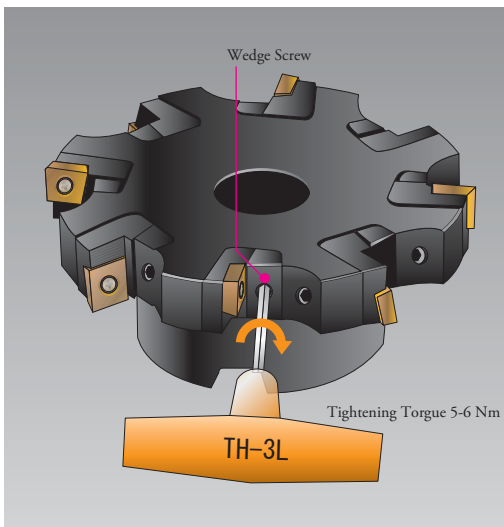
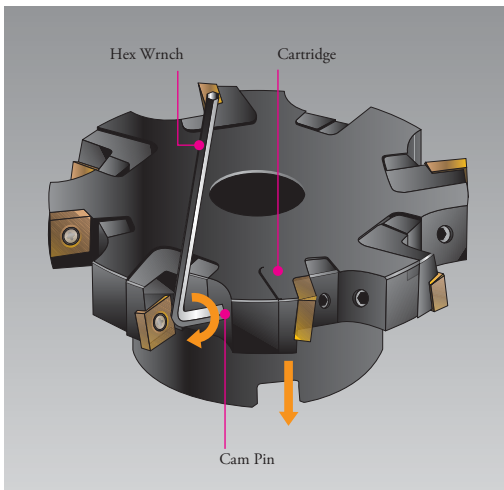
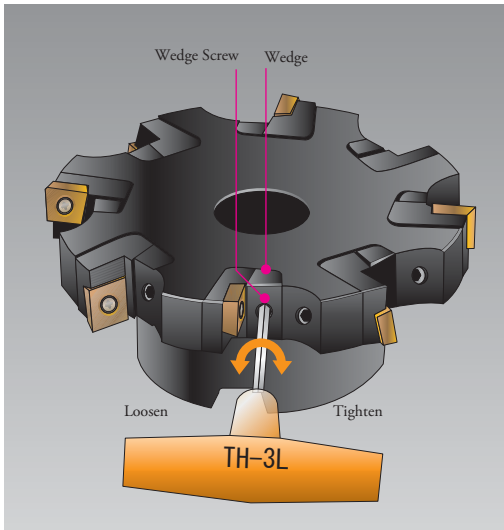

1. Set up the slot mill on length measuring equipment such as tool presettlers.
2. Insert a 3mm hex wrench (TH-3L) into the wedge screw.
3. Turn TH-3L counterclockwise to loosen the wedge.
4. Turn TH-3L clockwise by the torque of 1 Newton-meter (N-m) to tighten the wedge lightly and make the wedge to contact the cartridge and the slot mill body.  
In doing so, some resistance occurs against the cartridge.

5. Insert a hex wrench (LW-2.5 or LW-3) into the cam pin on the back of the cartridge.
6. Turn the wrench and adjust the position of the cartridge.
7. To secure the adjustment, back the cam pin off and make sure that it does not touch the groove surface of the back of the cartridge.
8. Remove the wrench from the cam pin.

9. Insert TH-3L into the wedge screw.
10. Tighten the wedge screw by the torque of 5 to 6 N-m.  
(Use a torque wrench to get the correct torque.)
11. Make sure there is no gap between the cartridge and the slot mill body.

Make sure there is no gap.

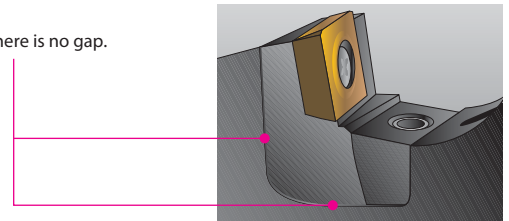

## Replacement of the cartridge.

Follow the instruction below to replace the cartridge.

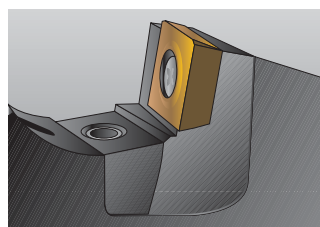
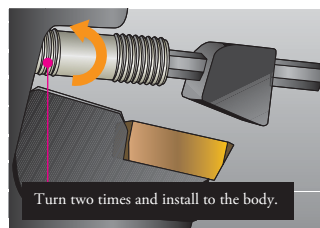
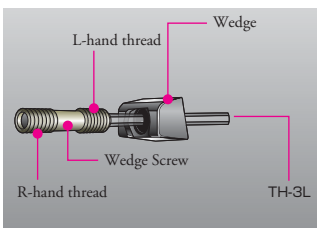
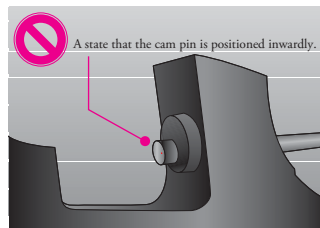
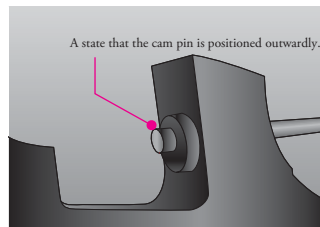
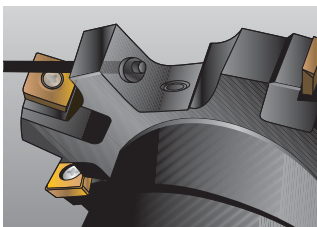
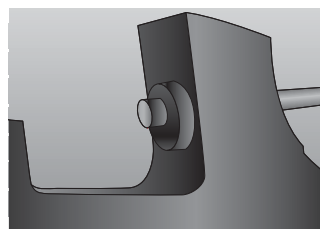
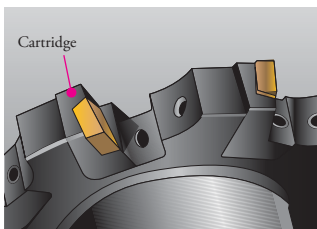
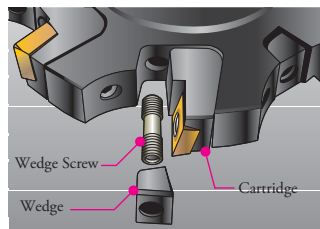
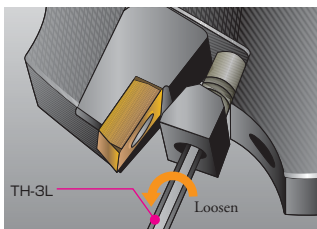
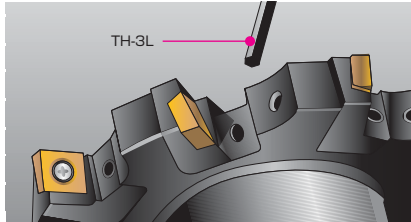

1. Insert a 3mm hex wrench (TH-3L) into the wedge screw.

2. Loosen the wedge screw.

3. Remove the wedge screw and the wedge.

4. Remove the cartridge.

5. Before replacing the cartridge, confirm that the cam pin is positioned radially-outwardly.

6. If the cam pin is in the position shown in the left diagram, assembling the cartridge is not possible.

7. Place the wedge so that its larger slant surface faces toward the cartridge.

8. Turn the wedge screw two times to install the wedge to the body.

9. When installing the wedge screw to the body, keep the wedge from rotating and screw it in.

10. Tighten the wedge screw by the torque of 5 to 6 N-m. Keep the screw head and the wedge even (prevent either of those from sticking out)

## ■ Example of applicable arbor for Slotting Cutter

Shape	See pages	Description		Bore Dia	BT Shank Arbor			
					BIG	NIKKEN	SHOWA	NT TOOL
Arbor Mount	3	MSTA	63N..	16		BT〇〇-SCA16..		BT〇〇-SCA16..
			80N..	16		BT〇〇-SCA16..		BT〇〇-SCA16..
			100N..	22		BT〇〇-SCA22..		BT〇〇-SCA22..
			125N..	32		BT〇〇-SCA32..		BT〇〇-SCA32..
			160N..	40		BT〇〇-SCA40..		BT〇〇-SCA40..
Shell Mount	7	MSTB	80SN..	22	BBT〇〇-FMC22..	BT〇〇-FMC22..	BT〇〇-FMC22..	BT〇〇-FMC22..
			100SN..	27	BBT〇〇-FMC27..	BT〇〇-FMC27..	BT〇〇-FMC27..	BT〇〇-FMC27..
			125SN..	40	BBT〇〇-FMB40..	BT〇〇-FMB40..	BT〇〇-FMB40..	BT〇〇-FMB40..
			160SN..	40	BBT〇〇-FMB40..	BT〇〇-FMB40..	BT〇〇-FMB40..	BT〇〇-FMB40..
	12	MSTC	100A〇..	32		BT〇〇-SCA32..		BT〇〇-SCA32..
	13		125A〇..	40		BT〇〇-SCA40..		BT〇〇-SCA40..
	14		160A〇..	40		BT〇〇-SCA40..		BT〇〇-SCA40..

THE NEW VALUE FRONTIER



www.kyocera.eu  
ceratip@kyocera.de

KYOCERA Fineceramics GmbH  
Cutting Tool Division  
Hammfelddamm 6, 41460 Neuss, Germany  
Phone: +49 (0) 2131 1637-115 Fax: +49 (0) 2131 1637-152  
www.kyocera.de

KYOCERA Fineceramics GmbH Italy Branch Office  
Cutting Tool Division  
Via Torino 51, 20123 Milan, Italy  
Phone: +39-02 00620 845 Fax: +39-02 00620 848  
www.kyocera.it

KYOCERA Fineceramics SAS.  
Cutting Tool Division,  
4, allée du Commandant Mouchotte, Paray-vieille-poste, 91781, Wissous Cedex, France  
Phone: +33 (0) 1 45 12 06 93 Fax: +33 (0) 1 56 72 18 94  
www.kyocera.fr

KYOCERA Fineceramics GmbH sp. z o.o. Poland Branch Office  
Cutting Tool Division  
Leg. ul. Europejska 4, 55-220, Jelcz-Laskowice, Poland  
Phone: +48-(0)71-381-12-15 Fax: +48-(0)71-381-12-16