



TA

MO

HT

VH

TSI/TSX

T

MT-TC-TC3

Accessori
Accessories

Appendice tecnica
Technical supplement

moltiplicatori di giri *spindle speeders*

I **moltiplicatori di giri** serie “MO” sono stati studiati e definiti con l'intento di offrire un prodotto che possa assicurare la massima affidabilità e precisione nelle operazioni di fresatura e foratura. Dalla progettazione al controllo statico e dinamico del prodotto finito, i nostri **moltiplicatori di giri** sfruttano le più avanzate conoscenze tecniche e tecnologiche.

- Giri max 35.000
- Utilizzati specialmente in operazioni di finitura
- Possibilità di montaggio manuale o automatico
- Consentono alla macchina di ruotare a bassi regimi di giri
- Possibilità di utilizzare utensili in metallo duro

La costruzione compatta, i componenti in acciaio trattato termicamente, gli ingranaggi rettificati sull'evolvente permettono la trasmissione di potenze elevate con ottimi livelli di silenziosità. Il mandrino è supportato da cuscinetti a sfere di precisione a contatto obliquo precaricati che gli conferiscono un'elevata rigidità e precisione di rotazione entro mm. 0,01.

- Due ingranaggi satelliti per elevate potenze trasmissibili
- Attacco utensile speciale a richiesta (Komet, DIN 1835, ecc...)
- Adduzione liquido refrigerante attraverso il centro utensile standard o a richiesta
- Attacco macchina speciale a richiesta (Cono Morse, DIN 69880, ecc...)
- Perno antirotante intercambiabile e perciò personalizzabile dal cliente

I **moltiplicatori di giri** possono essere montati su macchine tradizionali o con cambio utensile automatico.

La lubrificazione è assicurata con grasso a base sintetica a lunga vita che non richiede praticamente interventi di manutenzione.

Il certificato di collaudo che troverete allegato ad ogni **moltiplicatore di giri** garantisce la qualità del prodotto.

Robustezza, versatilità, facilità d'impiego e di manutenzione sono caratteristiche che hanno sempre contraddistinto la nostra produzione ed i **moltiplicatori di giri** ne sono una conferma.

The “MO” series of **spindle speeders** has been designed and developed to offer a product that ensures maximum reliability and precision in milling and drilling. From design to static and dynamic testing of the finished product, our **spindle speeders** use the most advanced technical and technological know-how.

- Max 35.000 rpm
- Used in particular for finishing operations
- Manual or automatic tool change option
- Allow the machine to rotate at low rpm
- Possibility of using hard metal tools

The compact construction, the heat-treated steel parts and the ground gears on the involute guarantee transmission of high power ratings with amazingly low noise levels. The spindle is supported by a set of preloaded precision ball bearings with oblique contact that ensure greater strength and rotation precision less than 0,01 mm.

- Two planetary gears for high transmission power ratings
- Special tool attachment on request (Komet, DIN 1835, etc.)
- Coolant through the tool centre standard or on request
- Special machine shank connection, on request (Morse Cone, DIN 69880 etc.)
- Interchangeable anti-rotating pin which can therefore be customized by the customer

The MO **spindle speeders** series can be mounted on traditional machines and on machines with automatic tool change.

The MO **spindle speeders** series is lubricated with a long-life synthetic grease that is practically maintenance free.

The test certificate enclosed to each spindle speeders guarantees the quality of the product.

Our products have always stood out for their sturdiness, flexibility and easy use and maintenance and the MO **spindle speeders** series is an additional proof of such outstanding features.

MO10.HS.....	2-2
MO10.....	2-3
MO13.....	2-4
MO16.....	2-5
MO26.....	2-6
MO34.....	2-7
Stop Block.....	2-8
Collaudo/Test result.....	2-9
Soluzioni speciali/Special executions....	2-10
Accessori/Accessories	8-1

Simboli/Icons



Pinza tipo ER
Spring collet ER type



Refrigerante centro cono-mandarino
Coolant through the centre shank-spindle



Refrigerante centro perno-ugello
Coolant through the pin-nozzle



Rapporto entrata/uscita
Ratio input/output



N° max giri in uscita
Max output RPM



Peso con cono 40
Weight with size 40 shank



Peso con cono 50
Weight with size 50 shank



Rotazione in ingresso
Input rotation



Rotazione in uscita
Output rotation

MO10.HS



caratteristiche/features



peso/weight



rotazione/rotation



prestazioni/performance

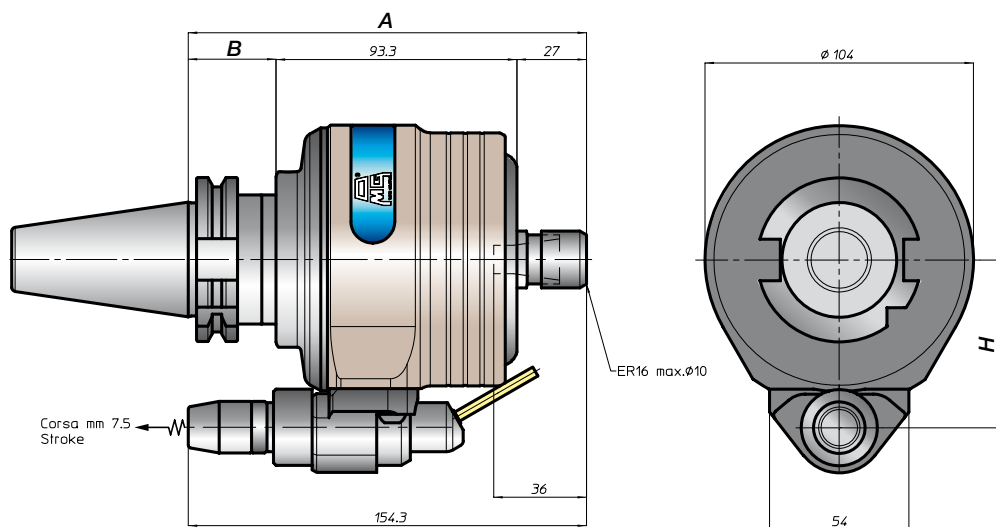
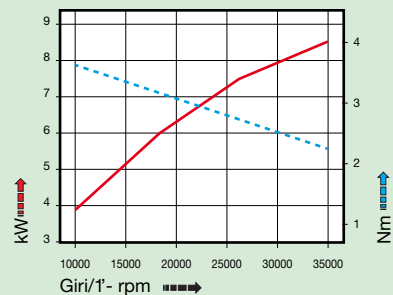

CONO SHANK	size	H			
		A	B	standard	optional
DIN69871	30	154	35	65	-
	40			80	
	45		42	80	
	50		42	80	
ANSIB5.50	40		35	65	-
	50		42	80	-
BT	40		35	65	-
	50		162	50	80
HSK	63		163	42	65
	80		167	42	-
	100	52		80	
CAPTO	C5	162	-	65	
	C6		80	-	
	C8		80	-	
KM	63	158	-	65	
	80		80	-	
	100		80	-	
DIN2080	-	-	-	-	
ANSIB5.18	-	-	-	-	

MO10



caratteristiche/features



peso/weight



rotazione/rotation



prestazioni/performance

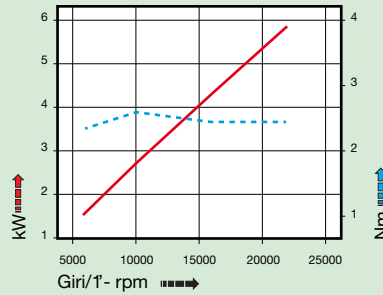

CONO SHANK	size	H		standard	optional
		A	B		
DING9871	30	131,5	35	65	-
	40				
	45		42	80	
	50				
ANSIB5.50	CAT 40	35	65	-	
	50	42	80	-	
BT	40	35	65	-	
	50	139,5	50	80	-
DING9893	HSK 63	140,5	42	65	-
	80	144,5	51	80	-
	100				
ISO26623	CAPTO C5	-	-	65	-
	C6	139,5	-	80	-
	C8	-	-	-	-
KM	63	135,5	-	65	-
	80			80	-
	100			-	-
DIN2080	40	101	12	65	-
	50	104,5	12	80	-
ANSIB5.18	NMTB 40	101	12	65	-
	50	104,5	12	80	-

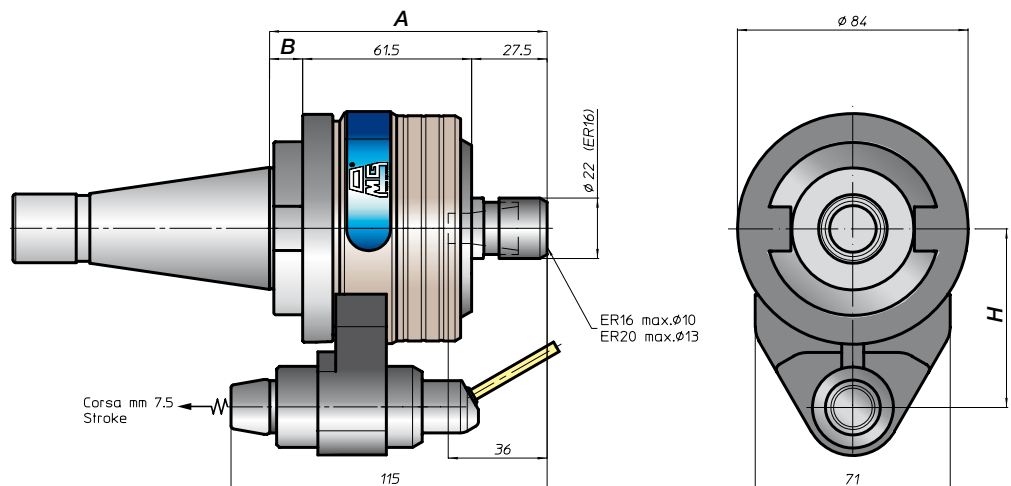
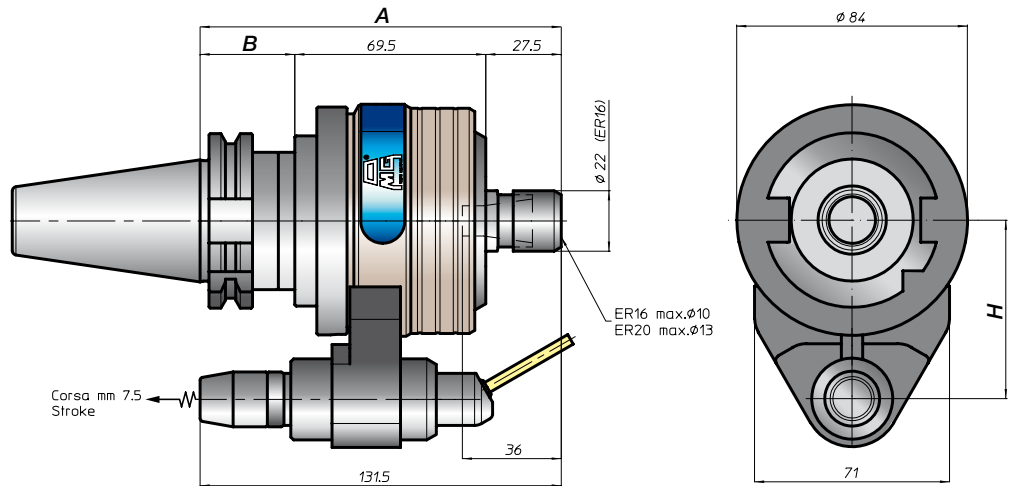

TA

MO

HT

VH

TSI/TSX

T

MT-TC-TC3

Accessori
Accessories

Appendice tecnica
Technical supplement

MO13



caratteristiche/features



peso/weight

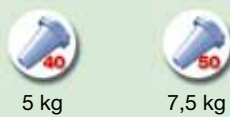

rotazione/rotation



prestazioni/performance

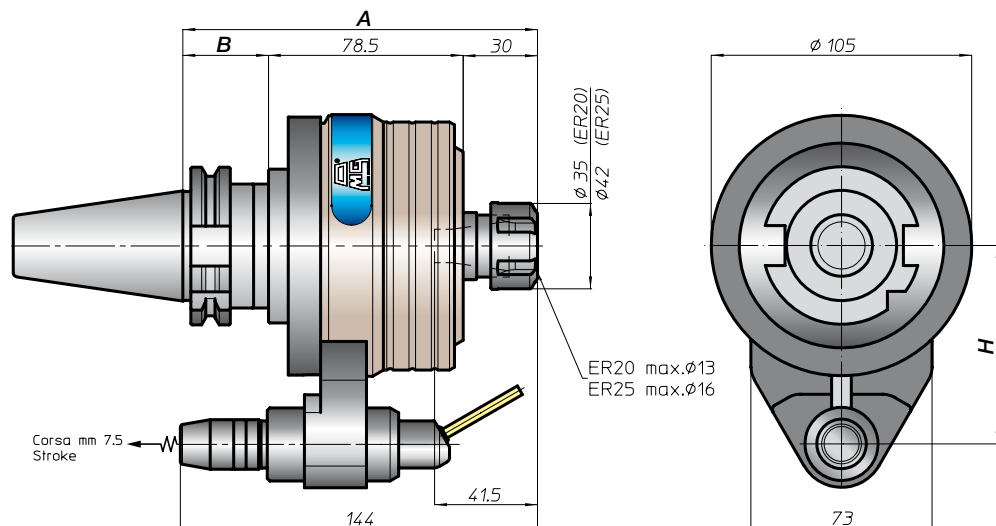
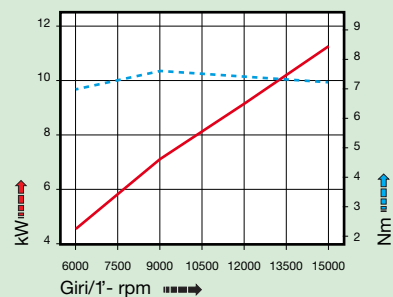

CONO SHANK	size	H			
		A	B	standard	optional
DIN9871	40	143	35	65	
	45				-
	50		42	80	
ANSIB5.50	40		35	65	-
	50		42	80	-
BT	40		35	65	-
	50	151	50	80	-
DIN69893	63	152		65	
	80		42		-
	100	156		80	
ISO26623	C5			65	
	C6	151	-		-
	C8			80	
KM	63			65	
	80	147	-		-
	100			80	
DIN2080	40	112,5	11,5	65	-
	50	116	15	80	-
ANSIB5.18	40	112,5	11,5	65	-
	50	116	15	80	-

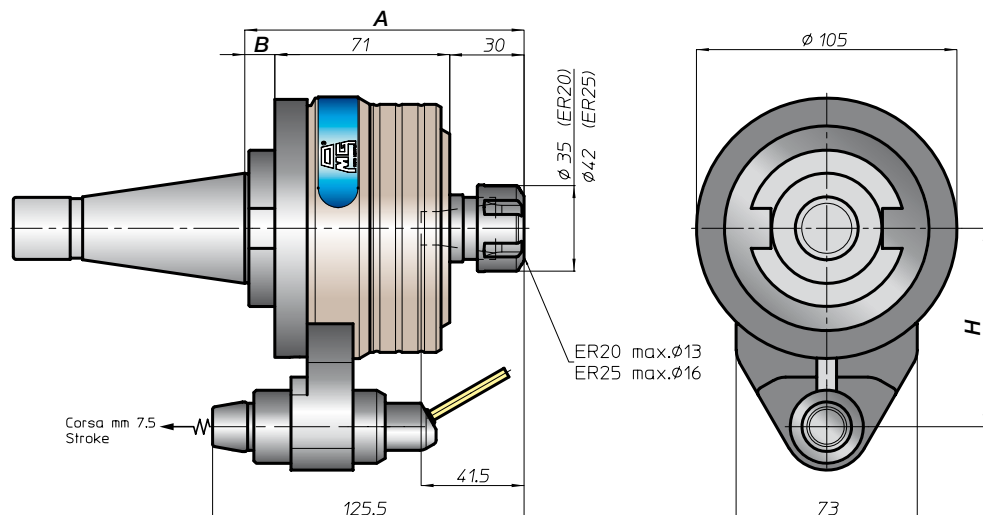

MO16

caratteristiche/features



peso/weight



rotazione/rotation



prestazioni/performance

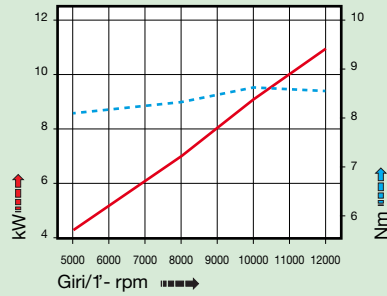

CONO SHANK	size	A	B	H	
				standard	optional
DING9871	45	158,5	35	80	-
	50		42	-	-
ANSIB5.50	50	164,5	35	80	-
	50		50	80	-
DING9893	80	165,5	42	80	-
	100		55	-	-
ISO26623	C6	164,5	-	80	-
	C8		-	-	-
KM	80	160,5	-	80	-
	100		-	-	-
DIN2080	40	128	11,5	65	-
	50	131,5	20	80	-
ANSIB5.18	40	128	11,5	65	-
	50	131,5	20	80	-

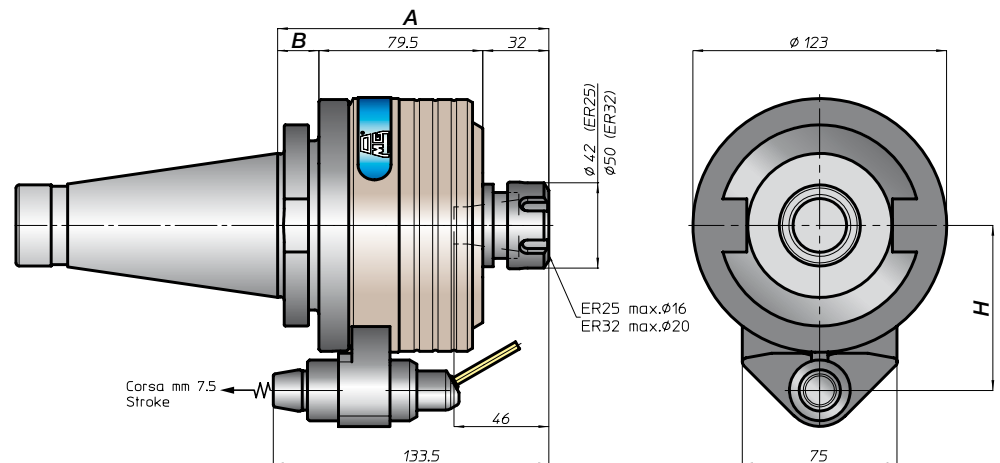
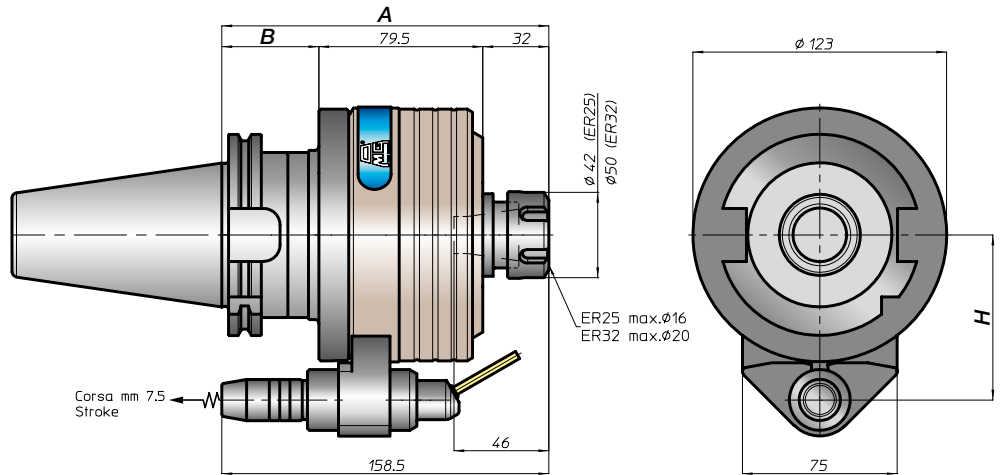

MO26



caratteristiche/features



peso/weight



rotazione/rotation



prestazioni/performance

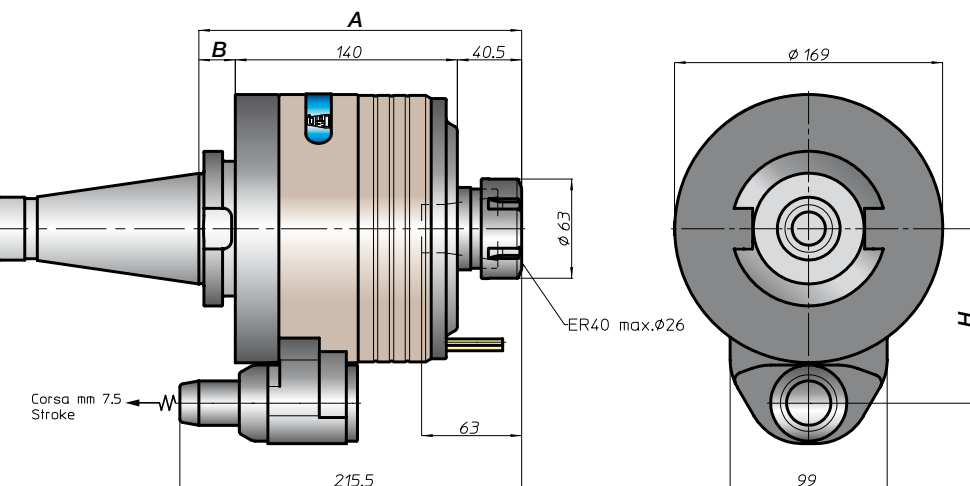
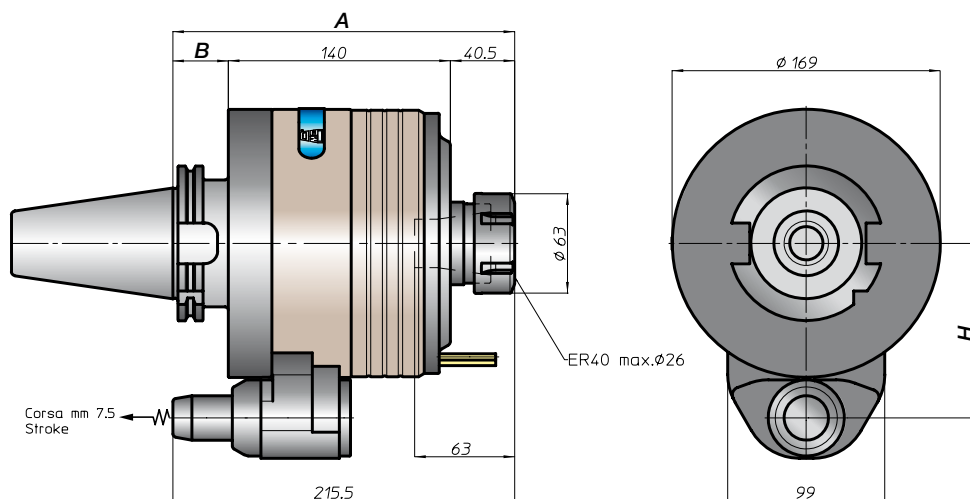
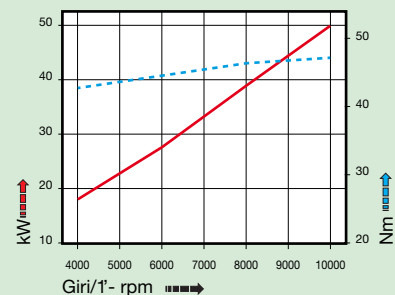

CONO SHANK	size	H		standard	optional
		A	B		
DIN9871	50	215,5	35	110	-
	60	229	48		
ANSIB5.50	50		35		-
		231,5		110	
BT	50		51		-
HSK	100	234	53	110	-
CAPTO	C8	229	-	110	-
KM	100	225	-	110	-
DIN2080	50	203,5	23	110	-
NMTB	50	203,5	23	110	-

MO34



caratteristiche/features



peso/weight



36 kg

rotazione/rotation

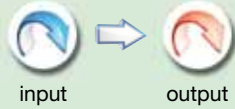

input

output

prestazioni/performance

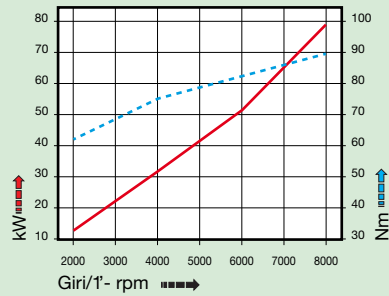

CONO SHANK	size	A	B	H	
				standard	optional
DIN69871	50	266	35	125	-
	60	272	41	-	-
ANSI B5.50	50	282	36	125	-
			51	-	-
DIN69893	100	284	46	125	-
ISO26623	C8	279	-	125	-
KM	100	275	-	125	-
DIN2080	50	254	23	125	-
ANSI B5.18	50	254	23	125	-

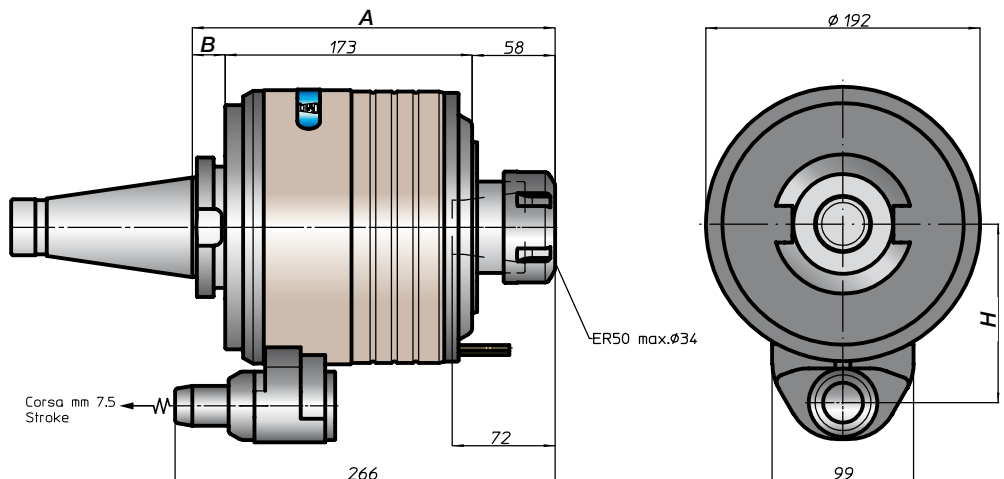
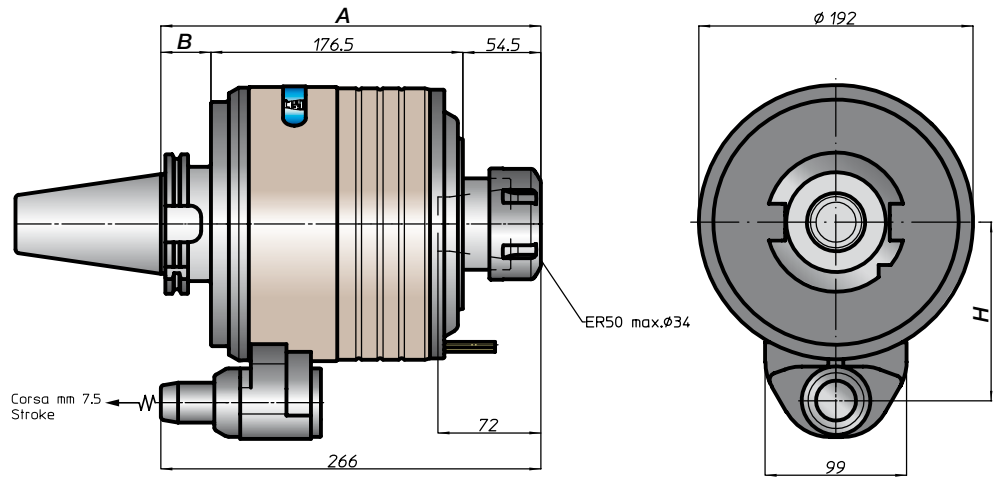

TA

MO

HT

VH

TSI/TSX

T

MT-TC-TC3

Accessori
Accessories

Appendice tecnica
Technical supplement

Stop-block

MO10.HS - MO10 - MO13 - MO16

Stop-block (cod. 630104)

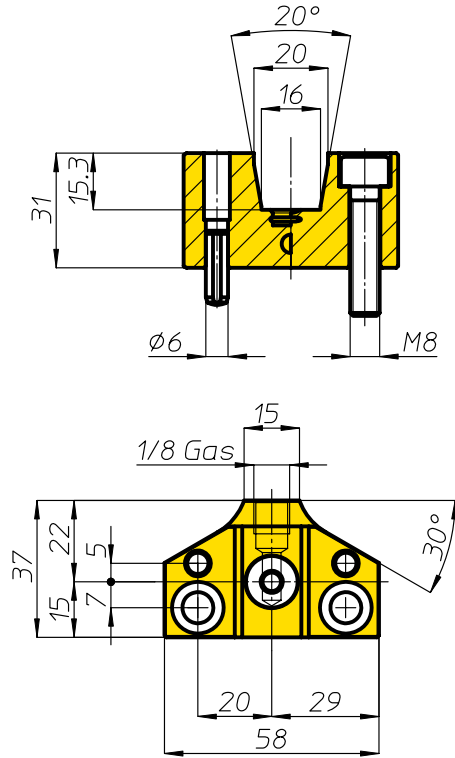

MO26 - MO34
Stop-block (cod. 632198)

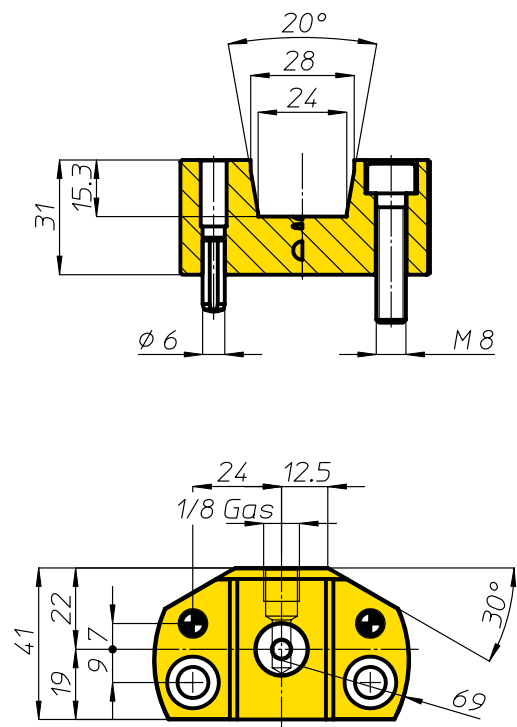



COLLAUDO

Ogni moltiplicatore di giri ha allegato il proprio certificato di collaudo dove sono riportate le proprie caratteristiche tecniche, il numero di matricola, i risultati ottenuti dai test eseguiti sul nostro banco prova BP03, il valore della concentricità tra il cono e la sede pinza il cui valore massimo è mm 0.01. Per verificare il valore della concentricità occorre disporre il moltiplicatore come in fig. 1, fermare il perno A e ruotare il cono. Il valore letto sul comparatore millesimale è la concentricità tra l'asse del cono e l'asse del mandrino.

TEST

Every spindle speeder has his test certificate in which there are the technical characteristics, the serial number, the results of the tests made on our BP03 testing bench, the concentricity value between the shank and the collet (max. value 0,01 mm). To verify the concentricity value it is necessary to have the spindle speeder as from picture N°. 1, stopping the pin "A" and rotating the shank. The value on the dial indicator is the concentricity between the shank axe and the spindle axe.

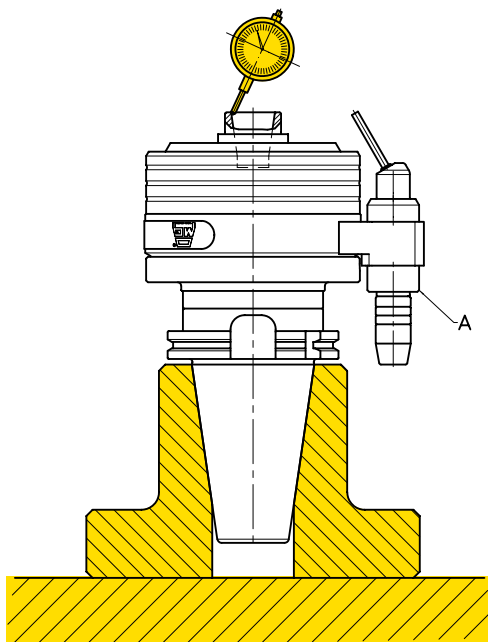

CERTIFICATO DI COLLAUDO

Banco prova BP03
Data prova: 10/07/2011
Articolo: MO10 Matricola: 1315

N° Max Giri Uscita: 22.000
Rapporto Entrata-Uscita: 1:6
N° Giri Uscita = N° Giri Entrata * Rapporto

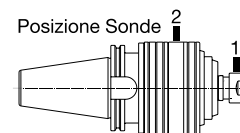

Prova	N° Giri Entrata	Temp.(°C) Sonda 1	Temp.(°C) Sonda 2	Temp. Ambiente
1	1000	45,40	43,20	24,60
2	1500	40,80	36,80	24,60
3	2000	44,20	42,00	24,80
4	2500	48,80	42,00	24,80
5	3000	49,20	38,60	25,00

Concentricità Max Cono - Mandrino: 0,006

TEST REPORT

Testing bench BP03
Test date: 10/07/2011
Item: MO10 SN: 1315

Max Output RPM: 22.000
Ratio Input-Output: 1:6
Output RPM = Input RPM * Ratio

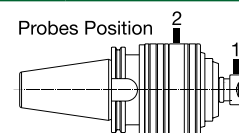

Test	Input RPM	Temp.(°C) Probe 1	Temp.(°C) Probe 2	Environment Temp.
1	1000	45,40	43,20	24,60
2	1500	40,80	36,80	24,60
3	2000	44,20	42,00	24,80
4	2500	48,80	42,00	24,80
5	3000	49,20	38,60	25,00

Max Runout between Shank and Spindle: 0,006

Moltiplicatori di giri speciali

Special spindle speeders



MO 26310

Riduttore di giri, rapporto 6-1,
input max 15.000 RPM, attacco
HSK63, mandrino ER20
*Spindle reducer, ratio 6-1, input
max 15.000 RPM, shank HSK63,
ER20 spindle*



MO 28910

MO16 con attacco CAPTO C8 e
mandrino ER25 prolungato
*MO16 with CAPTO C8 shank
and extended ER25 spindle*



MO 12110

Rapporto/Ratio 1-4
RPM max 4.500
Torque 1.150 Nm
Output DIN69871-A50
Peso/Weight Kg 240

Moltiplicatori di giri speciali

Special spindle speeders

TFS 09011

Riduttore di giri per maschiatura con compensazione assiale mandrino, corsa compensazione ± 7 mm, rapporto 6-1, input max 10.000 RPM, attacco HSK-F63, mandrino per bussola porta maschio grandezza 1
Tapping spindle reducer with axial compensation, stroke ± 7 mm, ratio 6-1, input max 10.000 RPM, shank HSK-F63, spindle for tapping bush size 1



VDI 16610

MO13 rinviato di 90° con attacco VDI30
MO13 with VDI30 shank at 90°

MO 16210

MO13 con attacco VDI40
MO13 with VDI40 shank



MO26 con cono DIN69871-A60, mandrino Weldon $\varnothing 25$ e liquido refrigerante utensile passante dal centro stop-block/centro mandrino
MO26 with DIN69871-A60 shank, output spindle Weldon $\varnothing 25$, coolant trough the stop-block/spindle centre