



MONOd'

Toolholders

Werkzeugaufnahmen

Portaherramientas

Porte-outils

Portautensili



Toolholders

Werkzeugaufnahmen

Portaherramientas

Porte-outils

Portautensili



p. 229



DIN 69893 HSK-A



ER
 WD
 PF
 CM
 MS

p. 14
 p. 15
 p. 16
 p. 17
 p. 17



p. 228



DIN 69871 AD+B

ER
 WD
 PF
 CM
 MS

p. 18 - 19
 p. 20 - 21
 p. 22
 p. 23
 p. 23



p. 228



MAS 403 BT AD+B

ER
 WD
 PF
 CM
 MS

p. 24 - 25
 p. 26 - 27
 p. 28
 p. 29
 p. 29



MONOd'

Toolholders

Werkzeugaufnahmen



12



MONOd' is a new line of monobloc toolholders by D'Andrea, which has been designed in addition to the worldwide well known Modulhard'Andrea and Toprun toolholder systems. Entirely produced by D'Andrea, the complete

MONOd' range is guaranteed by design, manufacturing sales procedures according ISO 9001 standard.

MONOd' line represents the perfect solution for all machine tool equipment: it guarantees users the advantages of excellent quality and a remarkable level of precision, while maintaining a highly competitive price.

MONOd', available in HSK 63 and 100, DIN 69871 and MAS-BT spindle versions, size ISO 40 and 50, comprises ER collet chuck holders, WD Weldon toolholders, PF mill holders, CM morse taper toolholders and MS tapping toolholders.

MONOd' AD+B

The entire program ISO 40 and 50 is built in the AD+B version. For using it in version B, remove the plugs from pos. B and utilise pull studs without hole (page 228). All of the mill-holders are equipped for coolants to be introduced.

MONOd' bezeichnet die von D'ANDREA neu entwickelte Serie von Monoblock-Werkzeughaltern, und ergänzt hiermit die bisherigen beiden bekannten Haltersysteme Modulhard'Andrea und Toprun.

Da die gesamte **MONOd'**-Serie vollständig bei D'ANDREA produziert wird, garantiert dies die Konstruktion, Fertigung und Verkaufsabwicklung nach ISO 9001 Standard.

Die **MONOd'**-Serie ist die perfekte Lösung für jede Maschinenausrüstung: Sie garantiert dem Anwender herausragende Qualität und höchste Genauigkeit zu absolut kostengünstigem Preis.

Das Kompletprogramm für Werkzeugspindeln HSK 63 und 100, DIN 69871 und MAS-BT in den Größen ISO 40 und 50 umfasst Spannzangenfutter ER, Werkzeugaufnahmen für Weldon WD, für Aufsteckfräser PF und Morsekegel CM sowie Aufnahmen mit eidschnellwechselfutter MS.

MONOd' AD+B

Das komplette Programm ISO 40 und 50 wird in Version AD+B ausgeführt. Für die Verwendung in Ausführung B muss der Stopfen von Position B entfernt und der Anzugsbolzen ohne Bohrung benutzt werden (Seite 208). Alle Fräseraufnahmen sind mit Kühlmittelbohrungen ausgestattet.

Portaherramientas

MONOd' es la nueva línea de portaherramientas monbloques, proyectada para completar los sistemas de portaherramientas modulhard'andrea y Toprun, ya conocidos en el mundo. Enteramente producida ed D'Andrea, la gama de portaherramientas

MONOd' es garantizada con procedimientos de proyecto, fabricación y venta conformes a las normas ISO 9001.

MONOd' representa la solución ideal para el equipado de toda las máquinas herramienta.

La línea **MONOd'** asegura a quienes la utilicen una calidad excelente y un grado de precisión elevado a un precio de mercado altamente competitivo.

El programa completo **MONOd'** para mandrinos de máquina HSK 63 y 100, DIN 69871 y MAS-BT en los tamaños ISO 40 y 50, comprende portapinzas ER, portaherramientas Weldon WD, portafresas PF, portaherramientas como morse CM y portaherramientas para roscar MS.

MONOd' AD+B

Todo el programa ISO 40 y 50 está realizado en la versión AD+B. Para su empleo en la versión B, quitar los tapones de la pos. B y utilizar tirantes sin orificio (página 228).

Todos los portafresas cuentan con un sistema de paso del líquido refrigerante.

Porte-outils

MONOd' est la nouvelle ligne de porte-outils monobloc D'Andrea qui complète les systèmes de porte-outils modulhard'andrea e Toprun, déjà connus dans le monde entier. Entièrement produit par D'Andrea, le système de porte-outils **MONOd'** est certifié selon les procédures d'étude, de fabrication et de vente des normes ISO 9001.

MONOd' représente la solution idéale pour l'équipement de toutes les machines outils.

MONOd' est en mesure d'assurer à l'utilisateur une excellente qualité et un remarquable degré de précision, associés à un prix hautement concurrentiel.

Le programme **MONOd'** en version HSK 63 et 100, DIN 69871 et MAS-BT de la grandeur ISO 40 et 50, comprend : porte-pinces ER, porte-outils Weldon WD, porte-fraises PF, porte-outils de taraudage MS.

MONOd' AD+B

Tout le programme ISO 40 et 50 est fait en version AD+B. Pour l'utilisation en version B, il faut enlever les bouchons de pos. B et utiliser les tirettes sans trou (page 228). Tous les porte fraises sont prédisposés pour le passage du liquide réfrigérant.

Portautensili

MONOd' è la nuova linea di portautensili monoblocco D'Andrea, progettata a completamento dei due sistemi già noti in tutto il mondo, Modulhard'Andrea e Toprun. Interamente prodotta in D'Andrea, la gamma dei portautensili **MONOd'** è garantita da procedure di progettazione, fabbricazione e vendita conformi alla norma ISO 9001.

La linea di portautensili **MONOd'** rappresenta la soluzione ideale per attrezzare ogni tipo di macchina utensile.

MONOd' garantisce all'utilizzatore i vantaggi dell'elevata qualità e dell'alto grado di precisione ad un prezzo di mercato altamente concorrenziale.

Il programma **MONOd'** nelle versioni HSK 63 e 100, DIN 69871 e MAS-BT a grandezza ISO 40 e 50 comprende portapinzas ER, in differenti lunghezze, Weldon WD, portafrese PF, riduzioni CM e maschiatori MS.

MONOd' AD+B

Tutto il programma ISO 40 e 50 è costruito in versione AD+B. Per l'impiego in versione B, togliere i tappi da pos. B ed utilizzare tiranti senza foro (pag.228). Tutti i portafrese sono predisposti per il passaggio del liquido refrigerante.

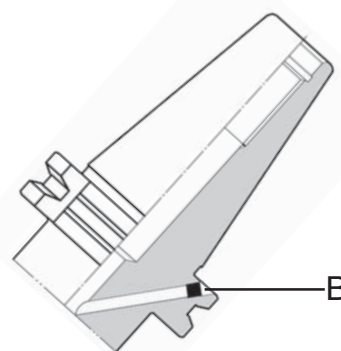

AD + B



Collet chuck holder

Spannzangenfutter

Portapinzas

Porte-pinces

Portapinze



14



ER

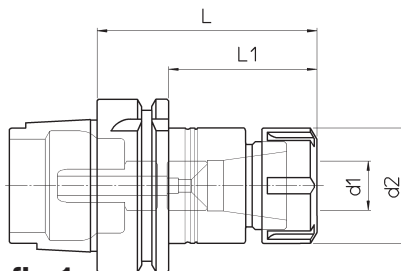

fig.1

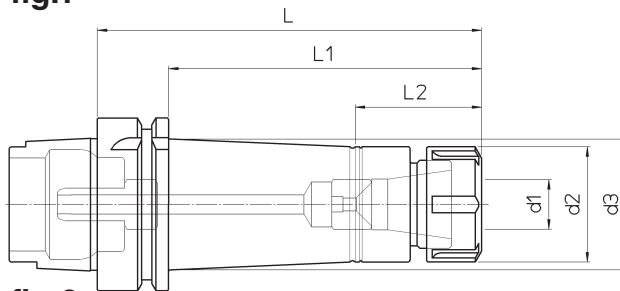

fig.2

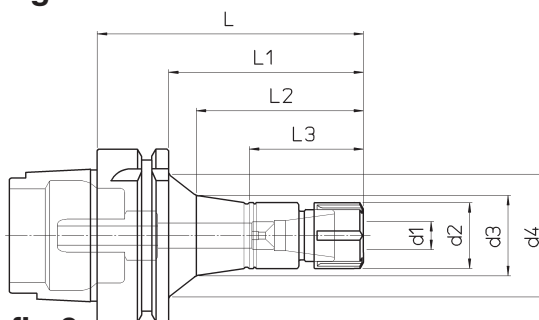

fig.3

Supplied with coolant tube - without collets and clamping wrenches

Lieferung inklusive Kühlmittelrohr. Ohne Spannzangen und Spannschlüssel.

Completo con racor para el refrigerante - Pinzas elásticas y llaves de apriete excluidas

Pourvu de raccord pour liquide d'arrosage - Sans pinces et clés de serrage

Completo di raccordo per il refrigerante - Pinze elastiche e chiavi di serraggio escluse

HSK-A	REF.	CODE	TYPE	d ₁	d ₂	d ₃	d ₄	L	L ₁	L ₂	L ₃	kg	fig.
63	HSK-A63 ER16.80	71HСКА063ER1608	ER 16 M	0.5 ~ 10	22	32		80	54	41		1.1	1
	HSK-A63 ER16.120	71HСКА063ER1612				31		120	94			1.9	2
	HSK-A63 ER25.80	71HСКА063ER2508	ER 25	1 ~ 16	42	-	80	54	-	-	1.3	1	
	HSK-A63 ER25.140	71HСКА063ER2514				47.5	140	114	46		1.7	2	
	HSK-A63 ER32.90	71HСКА063ER3209	ER 32	2 ~ 20	50	-	90	64	-	-	1.6	1	
	HSK-A63 ER32.160	71HСКА063ER3216				160	134	-	2.2		2		
100	HSK-A100 ER16.100	71HСКА100ER1610	ER 16 M	0.5 ~ 10	22	25	45	100	71	61	41.5	2.3	3
	HSK-A100 ER16.160	71HСКА100ER1616				34.5	44	160	131	126		2.5	
	HSK-A100 ER25.100	71HСКА100ER2510	ER 25	1 ~ 16	42	45.5		100	71	47	-	2.6	
	HSK-A100 ER25.160	71HСКА100ER2516				49.5		160	131			3.2	
	HSK-A100 ER32.120	71HСКА100ER3212	ER 32	2 ~ 20	50	55	-	120	91	52	-	3.1	2
	HSK-A100 ER32.160	71HСКА100ER3216				56.5		160	131			3.7	
	HSK-A100 ER40.120	71HСКА100ER4012	ER 40	3 ~ 26	63	71.5	-	120	91	60	-	3.5	

p. 269

p. 240

p. 230-233

p. 229

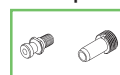
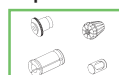

Weldon
toolholder

Werkzeugaufnahme
für Weldon

Portaherramienta
Weldon

Porte-outil
Weldon

Portautensile
Weldon

WD

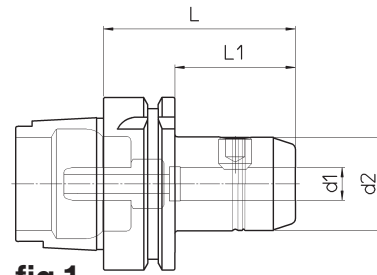

fig.1

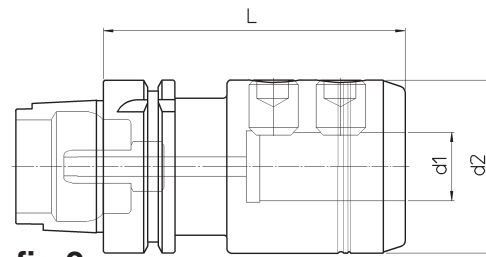

fig.2

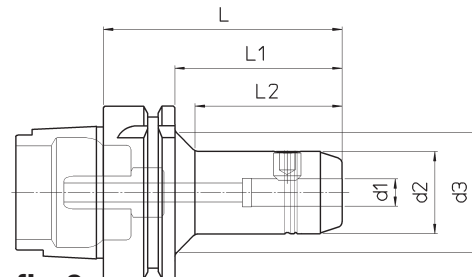

fig.3

Supplied with coolant
tube

Lieferung inklusive
Kühlmittelrohr

Completo con racor
para el refrigerante

Pourvu de raccord pour
liquide d'arrosage

Completo di raccordo
per il refrigerante

HSK-A	REF.	CODE	d ₁ ^{H5}	d ₂	d ₃	L	L ₁	L ₂	kg	fig.
63	HSK-A63 WD06.60	71HСКА063WD0606	6	23	-	60	34	-	0.8	1
	HSK-A63 WD08.65	71HСКА063WD0806	8	26		65	39		0.9	
	HSK-A63 WD10.70	71HСКА063WD1007	10	30		70	44		1.1	
	HSK-A63 WD12.70	71HСКА063WD1207	12	34		80	54		1.2	
	HSK-A63 WD16.80	71HСКА063WD1608	16	42		110	-		1.4	
	HSK-A63 WD20.80	71HСКА063WD2008	20	50		110	-		1.5	
	HSK-A63 WD25.110	71HСКА063WD2511	25	63		110	-		2.3	
	HSK-A63 WD32.110	71HСКА063WD3211	32	70		110	-		2.5	
100	HSK-A100 WD10.90	71HСКА100WD1009	10	30	45	90	61	53.5	2.3	3
	HSK-A100 WD12.100	71HСКА100WD1210	12	34		100	71	65.5	2.4	
	HSK-A100 WD14.100	71HСКА100WD1410	14	38		100	71	67.5	2.5	
	HSK-A100 WD16.100	71HСКА100WD1610	16	42	-	110	81	-	2.6	1
	HSK-A100 WD18.110	71HСКА100WD1811	18	46					3	
	HSK-A100 WD20.110	71HСКА100WD2011	20	50					3.1	
	HSK-A100 WD25.120	71HСКА100WD2512	25	63					3.9	
	HSK-A100 WD32.120	71HСКА100WD3212	32	70					4.3	
	HSK-A100 WD40.120	71HСКА100WD4012	40	80					120	

p. 229

p. 240

p. 269

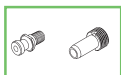

Mill holder

Werkzeugaufnahme
für Aufsteckfräser

Portafresa

Porte-fraises

Portafresa

PF

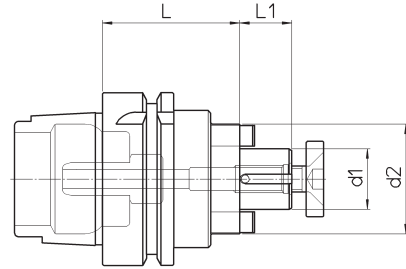
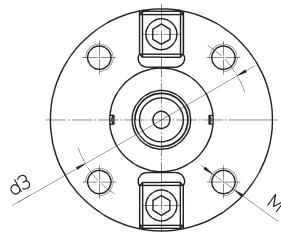
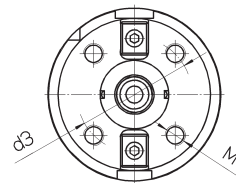

fig.1

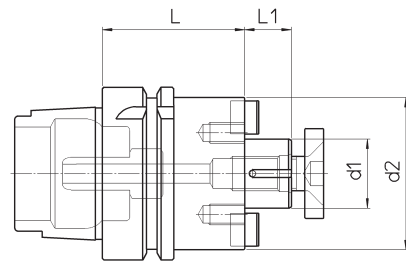

fig.2

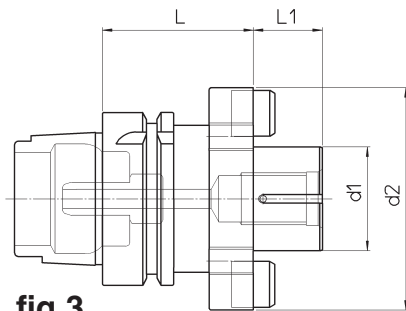

fig.3

Supplied with coolant
tube

Lieferung inklusive
Kühlmittelrohr.

Completo con racor
para el refrigerante

Pourvu de raccord pour
liquide d'arrosage.

Completo di raccordo
per il refrigerante

HSK-A	REF.	CODE	d ₁	d ₂	d ₃	M	L	L ₁	kg	fig.		
63	HSK-A63 PF16.50	71HСКА063PF1605	16	32	-	-	50	17	1.1	1		
	HSK-A63 PF22.50	71HСКА063PF2205	22	40				19	1.2			
	HSK-A63 PF27.55	71HСКА063PF2705	27	50				21	1.4			
	HSK-A63 PF32.60	71HСКА063PF3206	32	60			24	1.8				
100	HSK-A100 PF22.65	71HСКА100PF2265	22	40	-	-	65	19	2.3	2		
	HSK-A100 PF27.65	71HСКА100PF2765	27	50				21	2.5			
	HSK-A100 PF32.70	71HСКА100PF3270	32	60			70	24	2.9			
	HSK-A100 PF40.70	71HСКА100PF4070	40	88				66.7	M12		27	3.3
	HSK-A100 PF60.75	71HСКА100PF6075	60	128.5				101.6	M16		75	40

p. 269

p. 240

p. 229

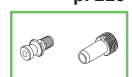

DIN 69893 HSK-A

CM - DIN 228 AB



D'ANDREA

Morse taper
toolholder

Werkzeugaufnahme
für Morsekegel

Portaherramienta
cono morse

Porte-outil cone
morse

Portautensile cono
morse

CM

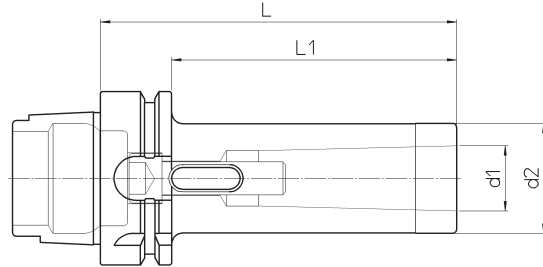

HSK-A	REF.	CODE	MORSE	d ₁	d ₂	L	L ₁	kg
63	HSK-A63 CM2.110 A-B	71HSKA063CMB211	2	17.780	32	110	84	2
	HSK-A63 CM3.130 A-B	71HSKA063CMB313	3	23.825	40	130	104	2.2
	HSK-A63 CM4.155 A-B	71HSKA063CMB415	4	31.267	48	155	129	2.6

DIN 69893 HSK-A

MS

Tapping toolholder

Aufnahme mit
Gewindeschneid-schnellwechselfutter

Portaherramienta
para roscar

Porte-outil de
taraudage

Portautensile
maschiatore

MS

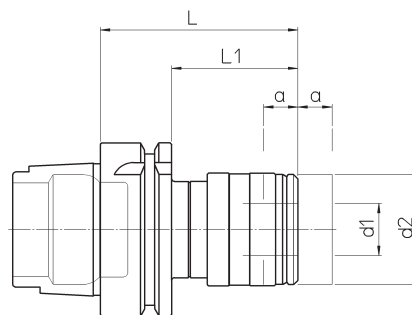

HSK-A	REF.	CODE	d ₁	d ₂	L	L ₁	a	kg
63	HSK-A63 MS1 M3-12	71HSKA063M10312	19	39	72	46	7.5	1
	HSK-A63 MS2 M8-20	71HSKA063M20820	31	60	110	84	10	1.7

p. 234-235

p. 269

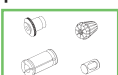

Collet chuck holder

Spannzangenfutter

Portapinzas

Porte-pinces

Portapinze

ER

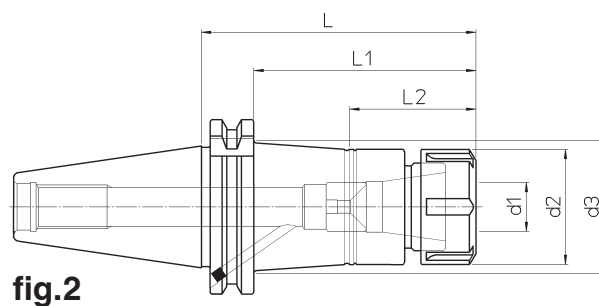
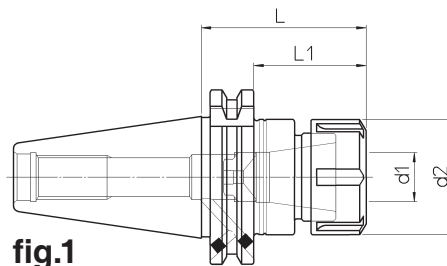

Supplied without collets and clamping wrenches

Ohne Spannzangen und Spannschlüssel.

Pinzas elásticas y llaves de apriete excluidas

Sans pinces et clés de serrage

Pinze elastiche e chiavi di serraggio escluse

DIN	REF.	CODE	TYPE	d ₁	d ₂	d ₃	L	L ₁	L ₂	kg	fig.
40	DIN69871-AD+B40 ER16.60	71DIN-B40ER1606	ER 16 M	0.5 ~ 10	22	-	60	41	-	0.9	1
	DIN69871-AD+B40 ER16.100	71DIN-B40ER1610				29.5	100	81	41	1	2
	DIN69871-AD+B40 ER16.160	71DIN-B40ER1616				38	160	141	41	2	2
	DIN69871-AD+B40 ER25.60	71DIN-B40ER2506	ER 25	1 ~ 16	42	-	60	41	-	1.1	1
	DIN69871-AD+B40 ER25.100	71DIN-B40ER2510				47	100	81	46	1.6	2
	DIN69871-AD+B40 ER25.160	71DIN-B40ER2516				50	160	141	46	2.1	2
	DIN69871-AD+B40 ER32.70	71DIN-B40ER3207	ER 32	2 ~ 20	50	-	70	51	-	1.2	1
	DIN69871-AD+B40 ER32.110	71DIN-B40ER3211				110	91	1.7			
	DIN69871-AD+B40 ER32.160	71DIN-B40ER3216				160	141	2.7			
	DIN69871-AD+B40 ER40.80	71DIN-B40ER4008	ER 40	3 ~ 26	63	-	80	61	-	1.3	1
	DIN69871-AD+B40 ER40.120	71DIN-B40ER4012				120	101	2.3			
	DIN69871-AD+B40 ER40.160	71DIN-B40ER4016				160	141	3.3			

p. 270

p. 240

p. 230-233

p. 228

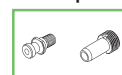
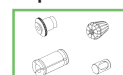

Collet chuck holder

Spannzangenfutter

Portapinzas

Porte-pinces

Portapinze

ER

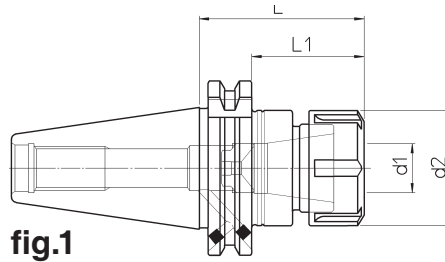

fig.1

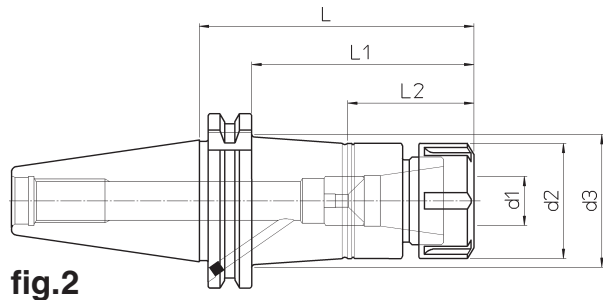

fig.2

Supplied without collets and clamping wrenches

Ohne Spannzangen und Spannschlüssel.

Pinzas elásticas y llaves de apriete excluidas

Sans pinces et clés de serrage

Pinze elastiche e chiavi di serraggio escluse

DIN	REF.	CODE	TYPE	d ₁	d ₂	d ₃	L	L ₁	L ₂	kg	fig.
50	DIN69871-AD+B50 ER16.100	71DIN-B50ER1610	ER 16 M	0.5 ~ 10	22	29.5	100	81	41	2.5	2
	DIN69871-AD+B50 ER16.160	71DIN-B50ER1616				32.5	160	141		3.3	
	DIN69871-AD+B50 ER25.70	71DIN-B50ER2507	ER 25	1 ~ 16	42	-	70	51	-	2.5	1
	DIN69871-AD+B50 ER25.110	71DIN-B50ER2511				48	110	91	2.8	2	
	DIN69871-AD+B50 ER25.160	71DIN-B50ER2516				50	160	141	3.6		
	DIN69871-AD+B50 ER32.70	71DIN-B50ER3207	ER 32	2 ~ 20	50	-	70	51	-	2.9	1
	DIN69871-AD+B50 ER32.110	71DIN-B50ER3211				55	110	91	3.4	2	
	DIN69871-AD+B50 ER32.160	71DIN-B50ER3216				57.5	160	141	4		
	DIN69871-AD+B50 ER40.100	71DIN-B50ER4010				ER 40	3 ~ 26	63	65		100
DIN69871-AD+B50 ER40.160	71DIN-B50ER4016	70	160	141	4.3						

p. 228

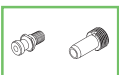

p. 230-233

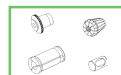

p. 240



p. 270



Weldon
toolholder

Werkzeugaufnahme
für Weldon

Portaherramienta
Weldon

Porte-outil
Weldon

Portautensile
Weldon



20

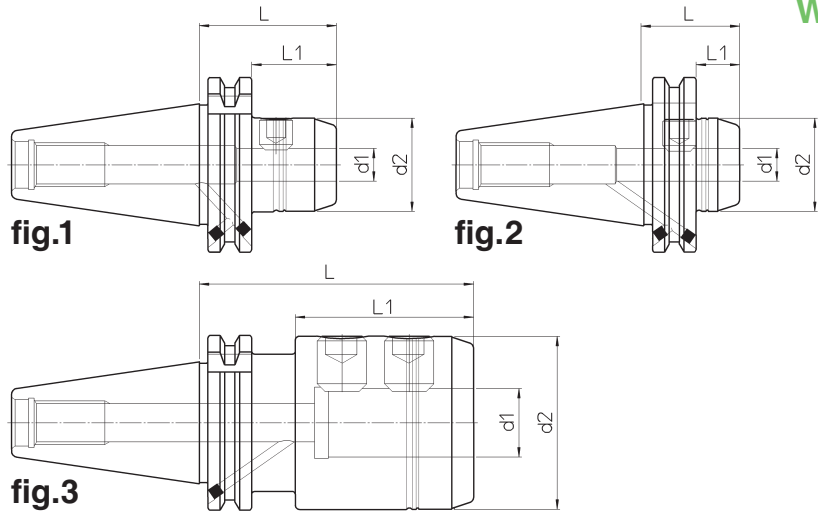

WD

DIN	REF.	CODE	d1 ^{H5}	d2	L	L1	kg	fig.
40	DIN69871-AD+B40 WD06.50	71DIN-B40WD0605	6	23	50	31	0.8	1
	DIN69871-AD+B40 WD06.110	71DIN-B40WD0611			110	91	1	
	DIN69871-AD+B40 WD06.160	71DIN-B40WD0616			160	141	1.1	
	DIN69871-AD+B40 WD08.50	71DIN-B40WD0805	8	26	50	31	0.9	
	DIN69871-AD+B40 WD08.110	71DIN-B40WD0811			110	91	1.1	
	DIN69871-AD+B40 WD08.160	71DIN-B40WD0816			160	141	1.3	
	DIN69871-AD+B40 WD10.50	71DIN-B40WD1005	10	30	50	31	1	
	DIN69871-AD+B40 WD10.110	71DIN-B40WD1011			110	91	1.4	
	DIN69871-AD+B40 WD10.160	71DIN-B40WD1016			160	141	1.6	
	DIN69871-AD+B40 WD12.35	71DIN-B40WD1203	12	34	35	16	1	2
	DIN69871-AD+B40 WD12.50	71DIN-B40WD1205			50	31	1.1	1
	DIN69871-AD+B40 WD12.110	71DIN-B40WD1211			110	91	1.4	
	DIN69871-AD+B40 WD12.160	71DIN-B40WD1216			160	141	1.7	
	DIN69871-AD+B40 WD14.50	71DIN-B40WD1405	14	38	50	31	1.2	
	DIN69871-AD+B40 WD14.110	71DIN-B40WD1411			110	91	1.6	
	DIN69871-AD+B40 WD16.35	71DIN-B40WD1603	16	42	35	16	1.1	2
	DIN69871-AD+B40 WD16.63	71DIN-B40WD1606			63	44	1.3	1
	DIN69871-AD+B40 WD16.110	71DIN-B40WD1611			110	91	1.7	
	DIN69871-AD+B40 WD16.160	71DIN-B40WD1616			160	141	2.2	
	DIN69871-AD+B40 WD18.63	71DIN-B40WD1806	18	46	63	44	1.4	
	DIN69871-AD+B40 WD18.110	71DIN-B40WD1811			110	91	1.9	
	DIN69871-AD+B40 WD20.35	71DIN-B40WD2003	20	44	35	16	1.2	2
	DIN69871-AD+B40 WD20.63	71DIN-B40WD2006			63	44	1.5	
	DIN69871-AD+B40 WD20.110	71DIN-B40WD2011		50	110	91	2.1	1
	DIN69871-AD+B40 WD20.160	71DIN-B40WD2016			160	141	2.6	
	DIN69871-AD+B40 WD25.35	71DIN-B40WD2503	25	63	44	35	1.3	2
	DIN69871-AD+B40 WD25.100	71DIN-B40WD2510			100	65	2	3
	DIN69871-AD+B40 WD25.160	71DIN-B40WD2516			160	125	3.2	
	DIN69871-AD+B40 WD32.100	71DIN-B40WD3210	32	70	100	65	2.5	
	DIN69871-AD+B40 WD32.160	71DIN-B40WD3216			160	125	3.9	

p. 270

p. 240

p. 228

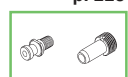

Weldon
toolholder

Werkzeugaufnahme
für Weldon

Portaherramienta
Weldon

Porte-outil
Weldon

Portautensile
Weldon

WD

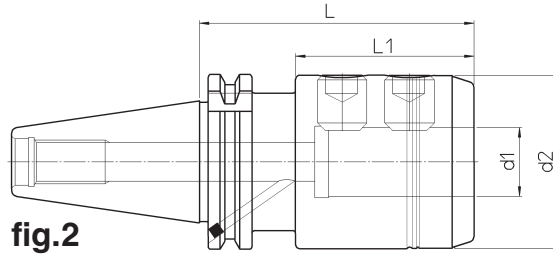
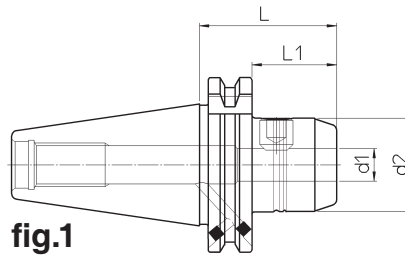

DIN	REF.	CODE	d ₁ ^{H5}	d ₂	L	L ₁	kg	fig.
50	DIN69871-AD+B50 WD06.63	71DIN-B50WD0606	6	23	63	44	2.3	1
	DIN69871-AD+B50 WD06.110	71DIN-B50WD0611			110	91	2.4	
	DIN69871-AD+B50 WD06.160	71DIN-B50WD0616			160	141	2.5	
	DIN69871-AD+B50 WD08.63	71DIN-B50WD0806	8	26	63	44	2.4	
	DIN69871-AD+B50 WD08.110	71DIN-B50WD0811			110	91	2.5	
	DIN69871-AD+B50 WD08.160	71DIN-B50WD0816			160	141	2.7	
	DIN69871-AD+B50 WD10.63	71DIN-B50WD1006	10	30	63	44	2.5	
	DIN69871-AD+B50 WD10.110	71DIN-B50WD1011			110	91	2.7	
	DIN69871-AD+B50 WD10.160	71DIN-B50WD1016			160	141	2.9	
	DIN69871-AD+B50 WD12.63	71DIN-B50WD1206	12	34	63	44	2.6	
	DIN69871-AD+B50 WD12.110	71DIN-B50WD1211			110	91	2.8	
	DIN69871-AD+B50 WD12.160	71DIN-B50WD1216			160	141	3.2	
	DIN69871-AD+B50 WD14.63	71DIN-B50WD1406	14	38	63	44	2.7	
	DIN69871-AD+B50 WD14.110	71DIN-B50WD1411			110	91	3	
	DIN69871-AD+B50 WD16.63	71DIN-B50WD1606	16	42	63	44	2.8	
	DIN69871-AD+B50 WD16.110	71DIN-B50WD1611			110	91	3.2	
	DIN69871-AD+B50 WD16.160	71DIN-B50WD1616			160	141	3.7	
	DIN69871-AD+B50 WD18.63	71DIN-B50WD1806	18	46	63	44	2.9	
	DIN69871-AD+B50 WD18.110	71DIN-B50WD1811			110	91	3.4	
	DIN69871-AD+B50 WD20.63	71DIN-B50WD2006	20	50	63	44	3	
	DIN69871-AD+B50 WD20.110	71DIN-B50WD2011			110	91	3.6	
	DIN69871-AD+B50 WD20.160	71DIN-B50WD2016			160	141	4.2	
	DIN69871-AD+B50 WD25.80	71DIN-B50WD2508	25	63	80	61	3.5	
	DIN69871-AD+B50 WD25.110	71DIN-B50WD2511			110	91	4.1	
DIN69871-AD+B50 WD25.160	71DIN-B50WD2516	160			141	5.1		
DIN69871-AD+B50 WD32.100	71DIN-B50WD3210	32	70	100	81	4.6		
DIN69871-AD+B50 WD32.160	71DIN-B50WD3216			160	141	6		
DIN69871-AD+B50 WD40.100	71DIN-B50WD4010	40	80	100	81	4.8		
DIN69871-AD+B50 WD40.160	71DIN-B50WD4016			160	141	6.5		

p. 228

p. 240

p. 270

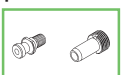

Mill holder

Werkzeugaufnahme
für Aufsteckfräser

Portafresa

Porte-fraises

Portafresa



22

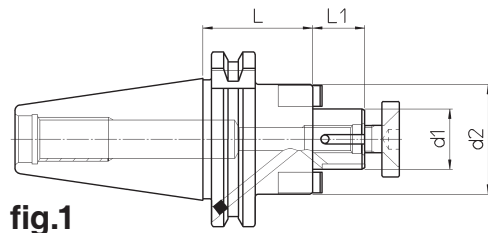
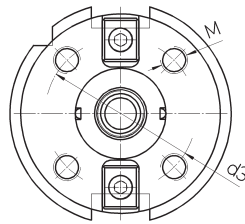

fig.1

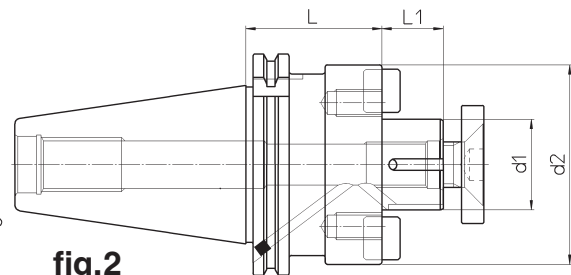

fig.2

PF

DIN	REF.	CODE	d ₁	d ₂	d ₃	M	L	L ₁	kg	fig.
40	DIN69871-AD+B40 PF16.35	71DIN-B40PF1603	16	32	-	-	35	17	0.9	1
	DIN69871-AD+B40 PF16.110	71DIN-B40PF1611					110		1.3	
	DIN69871-AD+B40 PF16.160	71DIN-B40PF1616					160		1.9	
	DIN69871-AD+B40 PF22.40	71DIN-B40PF2204	22	40			40	19	1	
	DIN69871-AD+B40 PF22.110	71DIN-B40PF2211					110		1.7	
	DIN69871-AD+B40 PF22.160	71DIN-B40PF2216					160		2.1	
	DIN69871-AD+B40 PF27.45	71DIN-B40PF2704	27	50			45	21	1.2	
	DIN69871-AD+B40 PF27.110	71DIN-B40PF2711					110		2.2	
	DIN69871-AD+B40 PF27.160	71DIN-B40PF2716					160		2.9	
	DIN69871-AD+B40 PF32.50	71DIN-B40PF3205	32	60			50	24	1.7	
	DIN69871-AD+B40 PF32.110	71DIN-B40PF3211					110		3	
	DIN69871-AD+B40 PF40.55	71DIN-B40PF4005	40	70			55	27	2.1	
50	DIN69871-AD+B50 PF16.40	71DIN-B50PF1604	16	32	40	17	2.4			
	DIN69871-AD+B50 PF16.110	71DIN-B50PF1611			110		2.8			
	DIN69871-AD+B50 PF16.160	71DIN-B50PF1616			160		3.1			
	DIN69871-AD+B50 PF22.45	71DIN-B50PF2204	22	40	45	19	2.6			
	DIN69871-AD+B50 PF22.110	71DIN-B50PF2211			110		3.2			
	DIN69871-AD+B50 PF22.160	71DIN-B50PF2216			160		3.7			
	DIN69871-AD+B50 PF27.50	71DIN-B50PF2705	27	50	50	21	2.7			
	DIN69871-AD+B50 PF27.110	71DIN-B50PF2711			110		3.6			
	DIN69871-AD+B50 PF27.160	71DIN-B50PF2716			160		4.4			
	DIN69871-AD+B50 PF32.55	71DIN-B50PF3205	32	60	55	24	3.2			
	DIN69871-AD+B50 PF32.120	71DIN-B50PF3212			120		5.5			
	DIN69871-AD+B50 PF40.60	71DIN-B50PF4006	40	88	66.7	M12	60	27	4.3	2
	DIN69871-AD+B50 PF40.120	71DIN-B50PF4012					120		7.1	
	DIN69871-AD+B50 PF60.70	71DIN-B50PF6007	60	128.5	101.6	M16	70	40	6.6	

p. 270

p. 240

p. 228

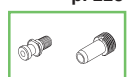

DIN 69871 AD+B

CM - DIN 228 AB



Morse taper
toolholder

Werkzeugaufnahme
für Morsekegel

Portaherramienta
cono morse

Porte-outil cone
morse

Portautensile cono
morse

CM

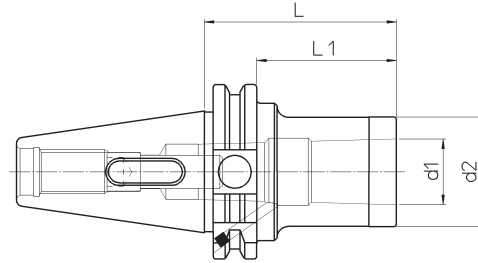

DIN	REF.	CODE	MORSE	d ₁	d ₂	L	L ₁	kg
40	DIN69871-AD+B40 CM2.50 A-B	71DIN-B40CMB205	2	17.780	32	50	31	1
	DIN69871-AD+B40 CM2.125 A-B	71DIN-B40CMB212				125	106	1.4
	DIN69871-AD+B40 CM3.70 A-B	71DIN-B40CMB307	3	23.825	40	70	51	1.1
	DIN69871-AD+B40 CM3.140 A-B	71DIN-B40CMB314			42	140	121	1.5
50	DIN69871-AD+B50 CM2.60 A-B	71DIN-B50CMB206	2	17.780	32	60	41	2.6
	DIN69871-AD+B50 CM2.125 A-B	71DIN-B50CMB212				125	106	2.8
	DIN69871-AD+B50 CM3.60 A-B	71DIN-B50CMB306	3	23.825	40	60	41	2.7
	DIN69871-AD+B50 CM3.140 A-B	71DIN-B50CMB314			42	140	121	3.2
	DIN69871-AD+B50 CM4.80 A-B	71DIN-B50CMB408	4	31.267	48	80	61	2.9

DIN 69871 A

MS

Tapping toolholder

Aufnahme mit
Gewindeschneidschnellwechselfutter

Portaherramienta
para roscar

Porte-outil de
taradage

Portautensile
maschiatore

MS

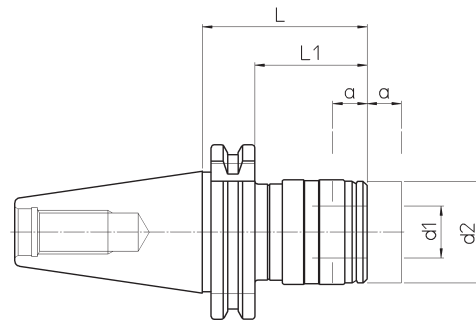

DIN	REF.	CODE	d ₁	d ₂	L	L ₁	a	kg
40	DIN69871-A40 MS1 M3-12	71DIN-A40M10312	19	36	60	40.9	7.5	0.9
	DIN69871-A40 MS2 M8-20	71DIN-A40M20820	31	53	98	78.9	12.5	1.3
50	DIN69871-A50 MS1 M3-12	71DIN-A50M10312	19	38	62	42.9	7.5	2.8
	DIN69871-A50 MS2 M8-20	71DIN-A50M20820	31	53	84	64.9	12.5	3.1
	DIN69871-A50 MS3 M14-33	71DIN-A50M31433	48	78	139	119.9	20	4.3

p. 228

p. 234-235

p. 270

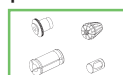
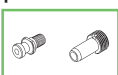

Collet chuck holder

Spannzangenfutter

Portapinzas

Porte-pinces

Portapinze

ER

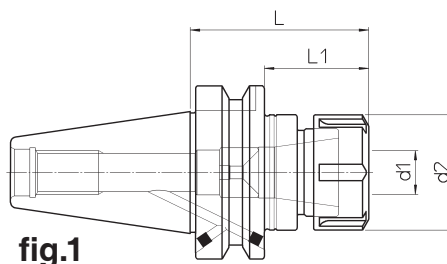

fig.1

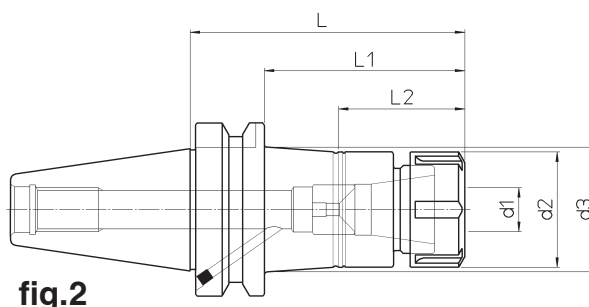

fig.2

Supplied without collets and clamping wrenches

Ohne Spannzangen und Spannschlüssel.

Pinzas elásticas y llaves de apriete excluidas

Sans pinces et clés de serrage

Pinze elastiche e chiavi di serraggio escluse

BT	REF.	CODE	TYPE	d ₁	d ₂	d ₃	L	L ₁	L ₂	kg	fig.
40	MAS403 BT40-AD+B ER16.60	71MBT-B40ER1606	ER 16 M	0.5 ~ 10	22	-	60	33	-	1	1
	MAS403 BT40-AD+B ER16.100	71MBT-B40ER1610				28	100	73	41	1.1	2
	MAS403 BT40-AD+B ER16.160	71MBT-B40ER1616				36.5	160	133	41	2.1	2
	MAS403 BT40-AD+B ER25.65	71MBT-B40ER2506	ER 25	1 ~ 16	42	-	65	38	-	1.2	1
	MAS403 BT40-AD+B ER25.100	71MBT-B40ER2510				45.5	100	73	46	1.7	2
	MAS403 BT40-AD+B ER25.160	71MBT-B40ER2516				49.5	160	133	46	2.2	2
	MAS403 BT40-AD+B ER32.70	71MBT-B40ER3207	ER 32	2 ~ 20	50	-	70	43	-	1.3	1
	MAS403 BT40-AD+B ER32.110	71MBT-B40ER3211				110	83	-	1.8		
	MAS403 BT40-AD+B ER32.160	71MBT-B40ER3216				160	133	-	2.8		
	MAS403 BT40-AD+B ER40.80	71MBT-B40ER4008	ER 40	3 ~ 26	63	-	80	53	-	1.4	1
	MAS403 BT40-AD+B ER40.120	71MBT-B40ER4012				120	93	-	2.4		
	MAS403 BT40-AD+B ER40.160	71MBT-B40ER4016				160	133	-	3.4		

p. 271

p. 240

p. 230-233

p. 228

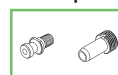
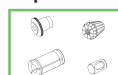

Collet chuck holder

Spannzangenfutter

Portapinzas

Porte-pinces

Portapinze

ER

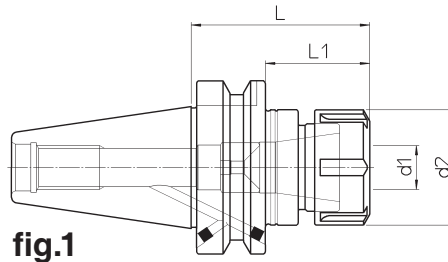

fig.1

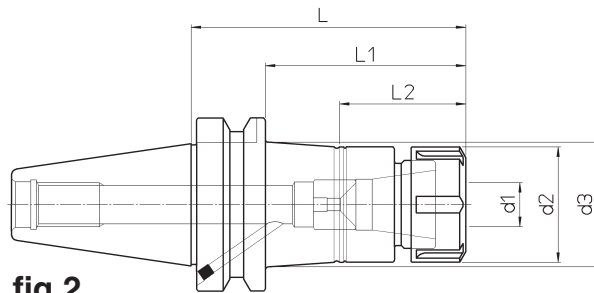

fig.2

Supplied without collets and clamping wrenches

Ohne Spannzangen und Spannschlüssel.

Pinzas elásticas y llaves de apriete excluidas

Sans pinces et clés de serrage

Pinze elastiche e chiavi di serraggio escluse

BT	REF.	CODE	TYPE	d ₁	d ₂	d ₃	L	L ₁	L ₂	kg	fig.
50	MAS403 BT50-AD+B ER16.100	71MBT-B50ER1610	ER 16 M	0.5 ~ 10	22	26.5	100	62	41	3.6	2
	MAS403 BT50-AD+B ER16.160	71MBT-B50ER1616				31	160	122		4.3	
	MAS403 BT50-AD+B ER25.75	71MBT-B50ER2507	ER 25	1 ~ 16	42	-	75	37	-	3.5	1
	MAS403 BT50-AD+B ER25.110	71MBT-B50ER2511				45.5	110	72	3.8		
	MAS403 BT50-AD+B ER25.160	71MBT-B50ER2516				48.5	160	122	4.6		
	MAS403 BT50-AD+B ER32.80	71MBT-B50ER3208	ER 32	2 ~ 20	50	-	80	42	-	3.9	1
	MAS403 BT50-AD+B ER32.110	71MBT-B50ER3211				52.5	110	72	4.4		
	MAS403 BT50-AD+B ER32.160	71MBT-B50ER3216				56	160	122	5		
	MAS403 BT50-AD+B ER40.100	71MBT-B50ER4010	ER 40	3 ~ 26	63	-	100	62	-	4.8	1
MAS403 BT50-AD+B ER40.160	71MBT-B50ER4016	68.5				160	122	5.3	2		

p. 228

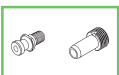

p. 230-233

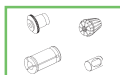

p. 240



p. 271



Weldon
toolholder

Werkzeugaufnahme
für Weldon

Portaherramienta
Weldon

Porte-outil
Weldon

Portautensile
Weldon



26

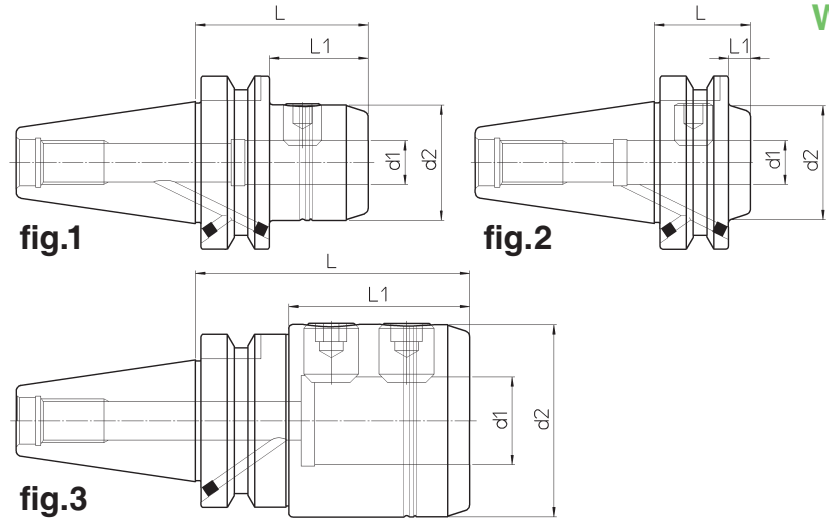

WD

BT	REF.	CODE	d1 ^{H5}	d2	L	L1	kg	fig.
40	MAS403 BT40-AD+B WD06.50	71MBT-B40WD0605	6	23	50	23	0.8	1
	MAS403 BT40-AD+B WD06.110	71MBT-B40WD0611			110	83	0.9	
	MAS403 BT40-AD+B WD06.160	71MBT-B40WD0616			160	133	1.1	
	MAS403 BT40-AD+B WD08.50	71MBT-B40WD0805	8	26	50	23	0.9	
	MAS403 BT40-AD+B WD08.110	71MBT-B40WD0811			110	83	1.1	
	MAS403 BT40-AD+B WD08.160	71MBT-B40WD0816			160	133	1.3	
	MAS403 BT40-AD+B WD10.56	71MBT-B40WD1005	10	30	56	29	1	
	MAS403 BT40-AD+B WD10.110	71MBT-B40WD1011			110	83	1.2	
	MAS403 BT40-AD+B WD10.160	71MBT-B40WD1016			160	133	1.5	
	MAS403 BT40-AD+B WD12.35	71MBT-B40WD1203	12	34	35	8	0.9	
	MAS403 BT40-AD+B WD12.56	71MBT-B40WD1205			56	29	1.1	1
	MAS403 BT40-AD+B WD12.110	71MBT-B40WD1211			110	83	1.4	
	MAS403 BT40-AD+B WD12.160	71MBT-B40WD1216			160	133	1.7	
	MAS403 BT40-AD+B WD14.56	71MBT-B40WD1405	14	38	56	29	1.2	
	MAS403 BT40-AD+B WD14.110	71MBT-B40WD1411			110	83	1.6	
	MAS403 BT40-AD+B WD16.35	71MBT-B40WD1603	16	42	35	8	1	2
	MAS403 BT40-AD+B WD16.63	71MBT-B40WD1606			63	36	1.3	1
	MAS403 BT40-AD+B WD16.110	71MBT-B40WD1611			110	83	1.7	
	MAS403 BT40-AD+B WD16.160	71MBT-B40WD1616			160	133	2.2	
	MAS403 BT40-AD+B WD18.63	71MBT-B40WD1806	18	46	63	36	1.4	
	MAS403 BT40-AD+B WD18.110	71MBT-B40WD1811			110	83	1.9	
	MAS403 BT40-AD+B WD20.35	71MBT-B40WD2003	20	50	35	8	1.1	2
	MAS403 BT40-AD+B WD20.63	71MBT-B40WD2006			63	36	1.5	1
	MAS403 BT40-AD+B WD20.110	71MBT-B40WD2011			110	83	2.1	
	MAS403 BT40-AD+B WD20.160	71MBT-B40WD2016			160	133	2.6	
	MAS403 BT40-AD+B WD25.35	71MBT-B40WD2503	25	63	35	8	1	2
	MAS403 BT40-AD+B WD25.100	71MBT-B40WD2510			100	73	2	3
	MAS403 BT40-AD+B WD25.160	71MBT-B40WD2516			160	133	3.2	
MAS403 BT40-AD+B WD32.100	71MBT-B40WD3210	32	70	100	67	2.5		
MAS403 BT40-AD+B WD32.160	71MBT-B40WD3216			160	127	3.9		

p. 271

p. 240

p. 228

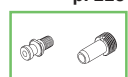

Weldon
toolholder

Werkzeugaufnahme
für Weldon

Portaherramienta
Weldon

Porte-outil
Weldon

Portautensile
Weldon

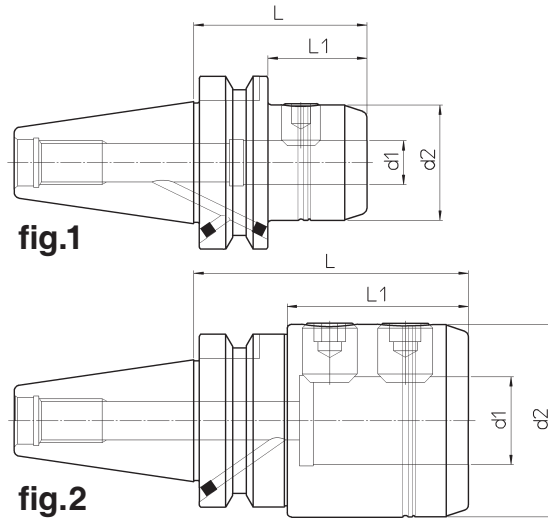

WD

27

BT	REF.	CODE	d ₁ ^{H5}	d ₂	L	L ₁	kg	fig.	
50	MAS403 BT50-AD+B WD06.63	71MBT-B50WD0606	6	23	63	25	2.3	1	
	MAS403 BT50-AD+B WD06.110	71MBT-B50WD0611			110	72	2.4		
	MAS403 BT50-AD+B WD06.160	71MBT-B50WD0616			160	122	2.6		
	MAS403 BT50-AD+B WD08.63	71MBT-B50WD0806	8	26	63	25	2.4		
	MAS403 BT50-AD+B WD08.110	71MBT-B50WD0811			110	72	2.5		
	MAS403 BT50-AD+B WD08.160	71MBT-B50WD0816			160	122	2.7		
	MAS403 BT50-AD+B WD10.70	71MBT-B50WD1007	10	30	70	32	3		
	MAS403 BT50-AD+B WD10.110	71MBT-B50WD1011			110	72	3.2		
	MAS403 BT50-AD+B WD10.160	71MBT-B50WD1016			160	122	3.4		
	MAS403 BT50-AD+B WD12.70	71MBT-B50WD1207	12	34	70	32	3.1		
	MAS403 BT50-AD+B WD12.110	71MBT-B50WD1211			110	72	3.3		
	MAS403 BT50-AD+B WD12.160	71MBT-B50WD1216			160	122	3.6		
	MAS403 BT50-AD+B WD14.70	71MBT-B50WD1407	14	38	70	32	3.2		
	MAS403 BT50-AD+B WD14.110	71MBT-B50WD1411			110	72	3.5		
	MAS403 BT50-AD+B WD16.80	71MBT-B50WD1608			16	42	80		42
	MAS403 BT50-AD+B WD16.110	71MBT-B50WD1611	110	72			3.5		
	MAS403 BT50-AD+B WD16.160	71MBT-B50WD1616	160	122			4		
	MAS403 BT50-AD+B WD18.80	71MBT-B50WD1808	18	46	80	42	3.4		
	MAS403 BT50-AD+B WD18.110	71MBT-B50WD1811			110	72	3.7		
	MAS403 BT50-AD+B WD20.80	71MBT-B50WD2008			20	50	80		42
	MAS403 BT50-AD+B WD20.110	71MBT-B50WD2011	110	72			3.8		
	MAS403 BT50-AD+B WD20.160	71MBT-B50WD2016	160	122			4.5		
	MAS403 BT50-AD+B WD25.100	71MBT-B50WD2510	25	63	100	62	4.5		2
	MAS403 BT50-AD+B WD25.125	71MBT-B50WD2512			125	87	5		
MAS403 BT50-AD+B WD25.160	71MBT-B50WD2516	160			122	5.7			
MAS403 BT50-AD+B WD32.100	71MBT-B50WD3210	32	70	100	62	5.6			
MAS403 BT50-AD+B WD32.160	71MBT-B50WD3216			160	122	7			
MAS403 BT50-AD+B WD40.110	71MBT-B50WD4011			40	80	110	72	5.8	
MAS403 BT50-AD+B WD40.160	71MBT-B50WD4016	160	122			7.4			

p. 228

p. 240

p. 271

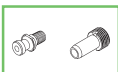

Mill holder

Werkzeugaufnahme
für Aufsteckfräser

Portafresa

Porte-fraises

Portafresa



28

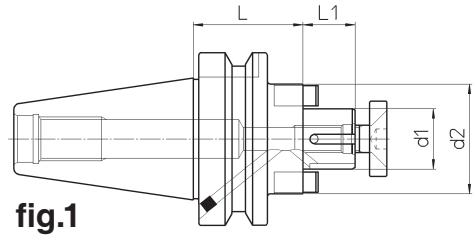
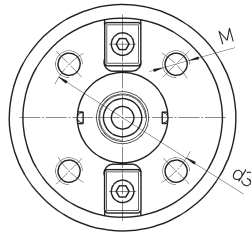

fig.1

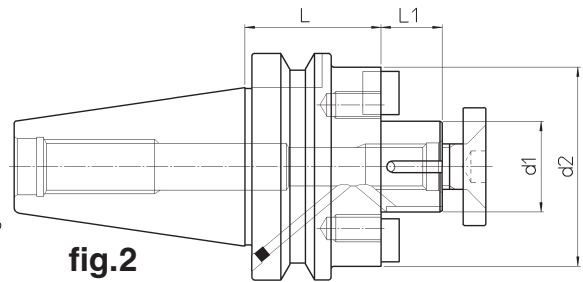

fig.2

PF

BT	REF.	CODE	d ₁	d ₂	d ₃	M	L	L ₁	kg	fig.
40	MAS403 BT40-AD+B PF16.40	71MBT-B40PF1604	16	32	-	-	40	17	0.9	1
	MAS403 BT40-AD+B PF16.110	71MBT-B40PF1611					110		1.3	
	MAS403 BT40-AD+B PF16.160	71MBT-B40PF1616					160		1.6	
	MAS403 BT40-AD+B PF22.40	71MBT-B40PF2204	22	40			40	19	1	
	MAS403 BT40-AD+B PF22.110	71MBT-B40PF2211					110		1.6	
	MAS403 BT40-AD+B PF22.160	71MBT-B40PF2216					160		2.1	
	MAS403 BT40-AD+B PF27.45	71MBT-B40PF2704	27	50			45	21	1.2	
	MAS403 BT40-AD+B PF27.110	71MBT-B40PF2711					110		2.2	
	MAS403 BT40-AD+B PF27.160	71MBT-B40PF2716					160		2.9	
	MAS403 BT40-AD+B PF32.50	71MBT-B40PF3205	32	60			50	24	1.7	
	MAS403 BT40-AD+B PF32.110	71MBT-B40PF3211					110		3	
	MAS403 BT40-AD+B PF40.55	71MBT-B40PF4005	40	70			55	27	2.1	
50	MAS403 BT50-AD+B PF16.50	71MBT-B50PF1605	16	32	50	17	2.4			
	MAS403 BT50-AD+B PF16.110	71MBT-B50PF1611			110		2.8			
	MAS403 BT50-AD+B PF16.160	71MBT-B50PF1616			160		3.1			
	MAS403 BT50-AD+B PF22.50	71MBT-B50PF2205			50		2.6			
	MAS403 BT50-AD+B PF22.110	71MBT-B50PF2211	22	40	110	19	3.2			
	MAS403 BT50-AD+B PF22.160	71MBT-B50PF2216			160		3.7			
	MAS403 BT50-AD+B PF27.55	71MBT-B50PF2705			55		2.7			
	MAS403 BT50-AD+B PF27.110	71MBT-B50PF2711	27	50	110	21	3.6			
	MAS403 BT50-AD+B PF27.160	71MBT-B50PF2716			160		4.3			
	MAS403 BT50-AD+B PF32.55	71MBT-B50PF3205			55		3.2			
	MAS403 BT50-AD+B PF32.120	71MBT-B50PF3212	32	60	120	24	5.5			
	MAS403 BT50-AD+B PF40.60	71MBT-B50PF4006			60		4.3			
	MAS403 BT50-AD+B PF40.120	71MBT-B50PF4012	40	88	66.7	M12	120	27	7.1	2
	MAS403 BT50-AD+B PF60.80	71MBT-B50PF6008					60	128.5	101.6	

p. 271

p. 240

p. 228

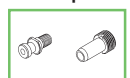

MAS 403 BT AD+B

CM - DIN 228 AB



Morse taper
toolholder

Werkzeugaufnahme
für Morsekegel

Portaherramienta
cono morse

Porte-outil cone
morse

Portautensile cono
morse

CM

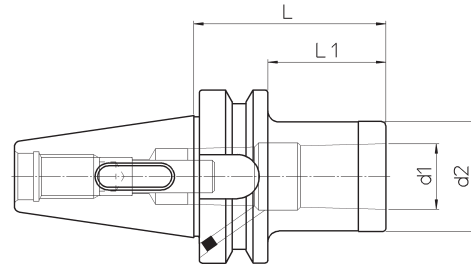

BT	REF.	CODE	MORSE	d ₁	d ₂	L	L ₁	kg
40	MAS403 BT40-AD+B CM2.50 A-B	71MBT-B40CMB205	2	17.780	32	50	23	1
	MAS403 BT40-AD+B CM2.125 A-B	71MBT-B40CMB212				125	98	1.3
	MAS403 BT40-AD+B CM3.70 A-B	71MBT-B40CMB307	3	23.825	40	70	43	1.1
	MAS403 BT40-AD+B CM3.140 A-B	71MBT-B40CMB314				140	113	1.5
50	MAS403 BT50-AD+B CM2.60 A-B	71MBT-B50CMB206	2	17.780	32	60	22	2.6
	MAS403 BT50-AD+B CM2.125 A-B	71MBT-B50CMB212				125	87	2.8
	MAS403 BT50-AD+B CM3.60 A-B	71MBT-B50CMB306	3	23.825	40	60	22	2.7
	MAS403 BT50-AD+B CM3.145 A-B	71MBT-B50CMB314				145	107	3.2
	MAS403 BT50-AD+B CM4.80 A-B	71MBT-B50CMB408	4	31.267	48	80	42	2.9

MAS 403 BT

MS

Tapping toolholder

Aufnahme mit
Gewindeschneid-schnellwechselfutter

Portaherramienta
para roscar

Porte-outil de
taraudage

Portautensile
maschiatore

MS

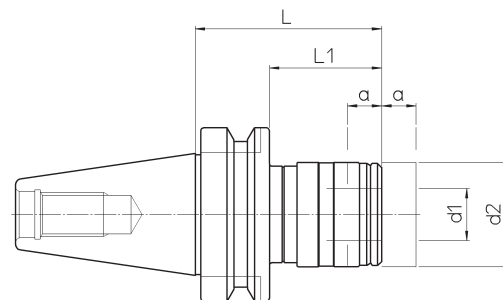

BT	REF.	CODE	d ₁	d ₂	L	L ₁	a	kg
40	MAS403 BT40 MS1 M3-12	71MBT-40-M10312	19	36	67.5	40.5	7.5	0.9
	MAS403 BT40 MS2 M8-20	71MBT-40-M20820	31	53	94.5	67.5	12.5	1.3
50	MAS403 BT50 MS1 M3-12	71MBT-50-M10312	19	38	80	42	7.5	2.8
	MAS403 BT50 MS2 M8-20	71MBT-50-M20820	31	53	102.5	64.5	12.5	3.1
	MAS403 BT50 MS3 M14-33	71MBT-50-M31433	48	78	154.5	116.5	20	4.3

p. 228

p. 234-235

p. 271

